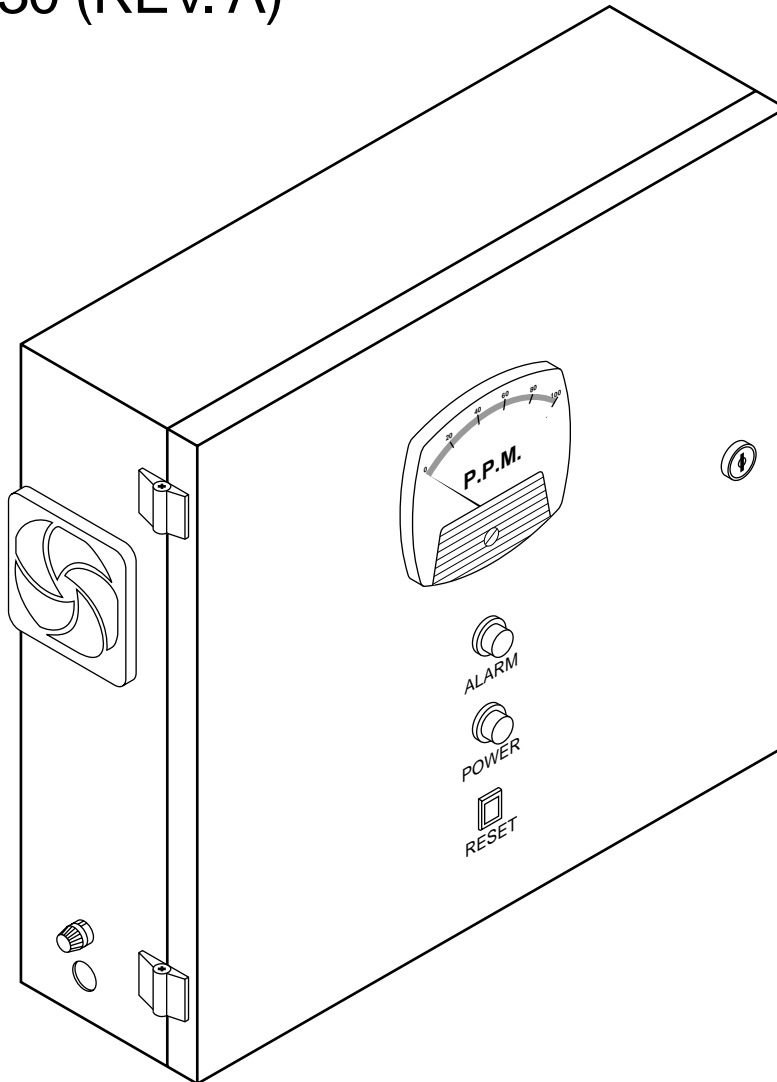




INSTALLATION & OPERATION MANUAL  
ENVIRONMENTAL SYSTEM 1000  
MODEL 1030 (REV. A)



SenTech Corporation  
5745 Progress Road  
Indianapolis, Indiana 46241  
Ph: 317/248-1988  
Fx: 317/247-5130



## INTRODUCTION/OVERVIEW

The SenTech Environmental System 1000, Model 1030 provides an early warning of developing refrigerant leaks. The unit continuously samples ambient air and measures the amount of halogen based refrigerant gases in the air sample. When the proportion of halogens present exceeds a trip point, the system goes into Alarm Mode notifying the user. By discovering the existence of a leak before the refrigerant loss has become great enough to be evident from a loss in equipment performance, the potential refrigerant loss is reduced saving money and helping protect the environment.

Model 1030 Specifications	
<b>Size:</b>	16 1/2" X 15" X 6 3/4" (42 cm X 38.1 cm X 17 cm)
<b>Weight:</b>	24 lbs (10.8 kgs)
<b>Power:</b>	120/240 Volt, 50/60 Hz (60 Watt) 100/200 Volt, 50/60 Hz (60 Watt)
<b>Temperature:</b>	32°- 125° Fahrenheit (0°- 50° Centigrade)
<b>Range:</b>	0 - 100 P.P.M. Standard 0 - 1000 P.P.M. (HFC's)
<b>Trip Point:</b>	0 - 100% of FS
<b>Leak Wait:</b>	Varies from seven (7) seconds to three (3) minutes depending on refrigerant concentration
<b>Alarm Output:</b>	Alarm Relay - Four (4) form C contacts rated 5 Amps maximum

### Basic Concept

Refer to the Model 1030 Block Diagram (Fig. 1). The diaphragm pump draws room air from the pickup tube, through the 5 micron filter, the orifice, and flowmeter into the sensor. The air flows across a heating element in the sensor which ionizes any halogen based molecules present. The ionized halogens cause a current to flow which is proportional to the amount of ions present. The microprocessor controlled circuitry measures the current and provides an output reading of the concentration in PPM (Parts per million). More critically, it compares the ppm level to a preset trip point. When the trip point is exceeded, the Model 1030 goes into Alarm Mode. In Alarm Mode, the alarm light flashes, the alarm relay is energized, and the sensor is deactivated to protect it from damage.

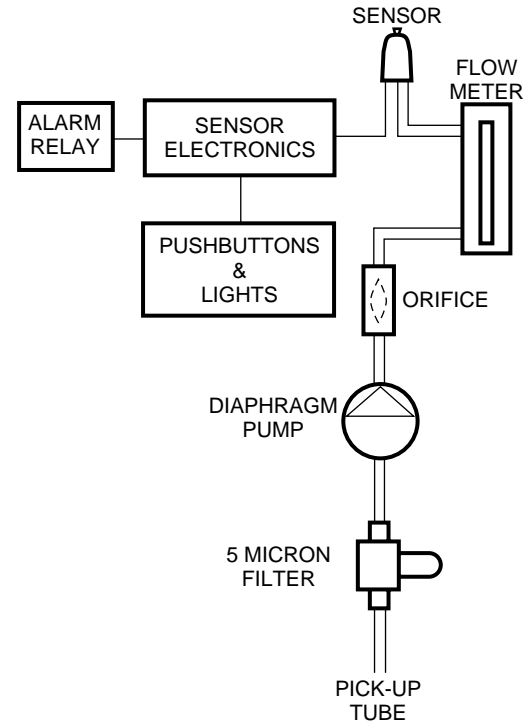


Fig. 1  
Model 1030 Block Diagram

### Sensitivity

The system is sensitive in varying amounts to all of the normal halogen based refrigerants, that is those molecules that contain either fluorine, chlorine, or both. Because of the variation in sensitivity each unit is calibrated at the factory for the specific refrigerant it is to monitor. In the event no refrigerant has been specified, it is calibrated for R-22. When appropriately calibrated, the Model 1030 can sense concentrations as low as 1 ppm (10-20 P.P.M. HFC's).

There is no direct relationship between the amount of refrigerant leaking and the concentration level being measured. The size of the room, the location of the monitor relative to the leak point, and the air pattern, all will affect the actual concentration at the monitor. However, by judicious location of the monitor (see installation section) and maintaining the trip point at a level not too far above the ambient, leaks should be detected substantially before they otherwise would be noticed.

# INSTALLATION

## Location

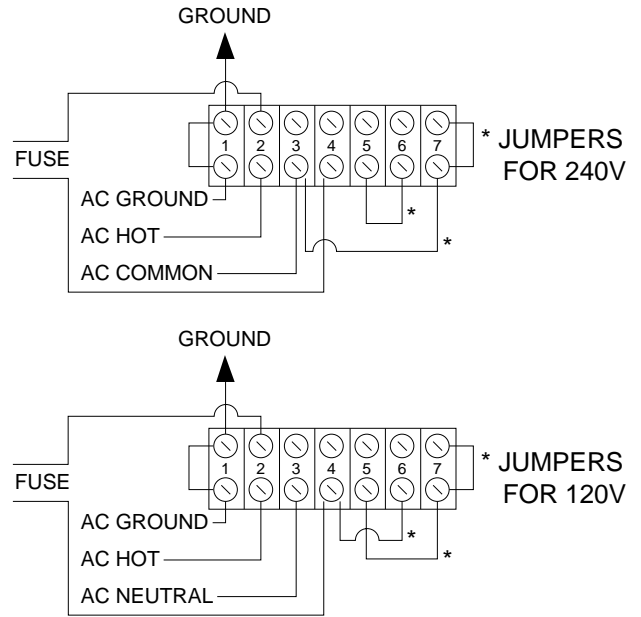
Since the sensor measures the concentration of refrigerant in air, the unit should be mounted where it is most likely to sense leaking refrigerant. The criteria to consider in selecting a location include:

As close to the area of potential leaks as possible. On the “downstream” side of the air flow pattern in the room.

The cooling and exhaust openings should be well clear of any obstructions, allowing the air to flow freely.

Since refrigerants are typically heavier than air, the pickup tube should be terminated 20 inches (50 cm) above the floor.

The unit includes sensitive electronics and a sensor operating at 900 degrees Celsius, the area should be free from vibration to the extent practical.



NOTE: UNITS FOR USE IN JAPAN ARE 100V/200V.

**Fig. 2**  
**Primary Power Wiring Diagram**

## Mounting and Primary Power Wiring

Packed within the Model 1030 is the container for the sensor and the CTS/Warranty card which is to be completed and returned after start-up.

1. Drill the necessary holes and mount the unit.
2. Mount the filter and secure the pickup tube.
3. Unpack the sensor and carefully insert the sensor into its socket. Make certain that the sensor is well seated.

Refer to wiring diagram(Fig. 2). Primary power should be supplied to the unit through the bushing located on the left side of the box. It is strongly recommended that power be supplied from a separate disconnect, **NOT** by plugging in to a wall socket. The Model 1030 is a continuous monitor. If a wall socket is used, there is a risk that the unit will inadvertently be unplugged putting it off line.

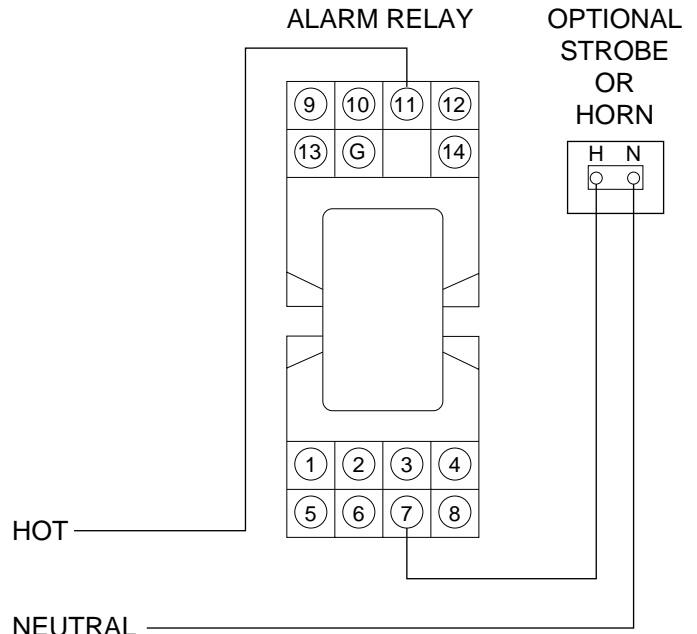
## OPTIONAL CONNECTIONS

Using customer supplied power, warning lights and or horns are to be connected in the manner shown (Fig. 3). Use an auxiliary contactor for heavy loads such as exhaust fans. Note: Alarm relay contacts are rated 5 Amps maximum.

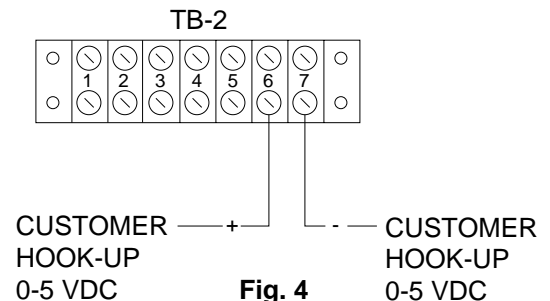
The analog output is available at TB-2 (Fig. 4). Terminal 6 is the positive side of the output and terminal 7 is the negative side of the output.

## RS485 Communications Port

Refer to the instruction material provided with this option.

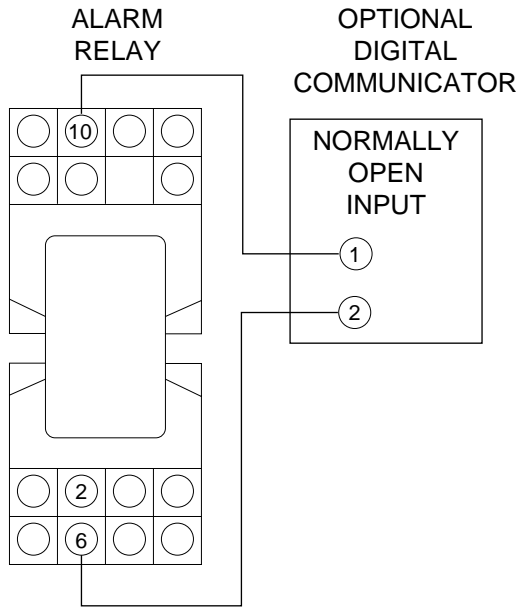


**Fig. 3**  
**Option Connection Wiring Diagram**



**Fig. 4**  
**Analog Output**

## Automatic Digital Communicator



**Fig. 5**  
**Optional Digital Communicator**

After double checking the wiring, turn to the section on Start-up and Operations before applying primary power.

## START-UP AND OPERATIONS

Before applying primary power to the Model 1030, read this section in its entirety.

### WARNING

**THE SENSOR OPERATES AT A TEMPERATURE OF 90° CELSIUS (165° FAHRENHEIT). IF THERE IS ANY REASON TO SUSPECT THE PRESENCE OF A COMBUSTIBLE ATMOSPHERE, THE SYSTEM SHOULD NOT BE TURNED ON UNTIL THAT HAS BEEN ELIMINATED.**

### Modes of Operation

The Model 1030 has 5 modes or states that it can be in. These are:

#### Warm-up:

When power is applied or after an alarm condition has been reset, the system goes through a 3 minute warm-up period.

#### Monitoring:

After warm-up, the system goes into Monitor Mode. It is continuously sampling ambient air and providing readout of the refrigerant concentration.

#### Leak Wait:

When the concentration of refrigerant in the ambient air exceeds the preset trip point, the system enters the Leak Wait Mode. The system stays in leak wait for a period of time ranging from 7 seconds to 3 minutes. The larger the ppm reading the shorter the wait period. The purpose of the wait is to avoid going into alarm for a brief transient increase in halogen background. During Leak Wait the PPM meter oscillates between 0 and the ppm reading.

#### Alarm:

After the leak wait timing is complete, the system enters the Alarm Mode. The alarm light flashes, the alarm relay is energized, the meter is steady at the last ppm reading, and power to the sensor is shut off to protect it. The system remains in Alarm Mode until the reset push-button is depressed.

**Note:** Systems for use with refrigerant R123 (software release 20) do not shut down during Alarm Mode. They continue to measure the actual refrigerant concentration. The system remains in Alarm Mode even if the concentration falls below the trip point. The Reset push-button must be depressed to clear the Alarm Mode.

#### Test:

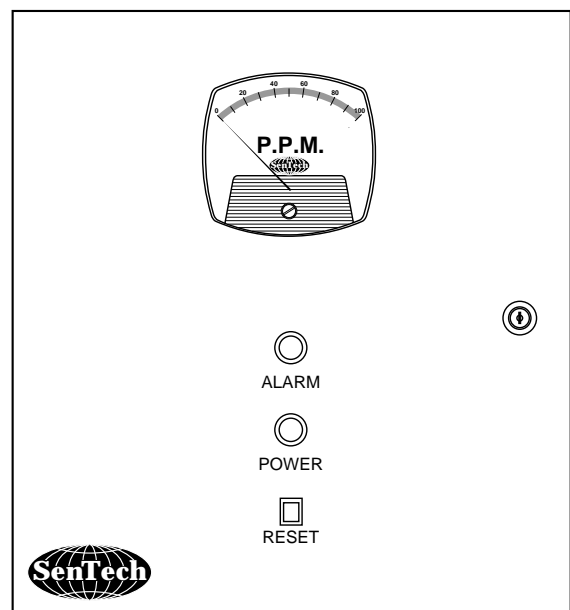
Test Mode is selected by one of the DIP switch positions in the monitor. The test mode bypasses all other modes and it is for maintenance purposes only.

### WARNING

**NEVER LEAVE THE SYSTEM IN TEST MODE SINCE IT WILL NOT ALARM IN THE PRESENCE OF A LEAK.**

#### Controls and Displays:

The front panel contains the output meter, two display lights and a reset push-button (Fig. 6).



**Fig. 6**  
**Front Panel**

**Power Light:**

A green light indicating that power is applied to the monitor.

**Alarm Light:**

The alarm light has several functions. When power is first applied to the unit, or when the reset push-button is depressed, the light flashes 3 times indicating the start of the warm-up period. During normal monitoring, the light is off. In the Leak Wait Mode, the light is off. In the Alarm Mode, the light flashes and continues to flash until the reset push-button is depressed. In Test Mode, the alarm light is on continuously warning that the unit is in Test Mode.

**Reset Push Button:**

The reset push-button resets the unit from an alarm condition. If the ambient level of refrigerant still exceeds the trip point the unit will go back into an alarm condition after warm-up and leak wait.

**PPM Meter:**

The PPM meter provides a display of ambient refrigerant levels in parts per million during the normal or monitoring mode. In Start-up Mode, the meter reads 0 ppm. During leak wait, the meter oscillates between 0 and the refrigerant level present, providing an indication that the unit is in Leak Wait mode. In Alarm Mode, the meter displays the level of refrigerant present when the system went into alarm (Systems configured for R123 continue to display actual concentration). In Test Mode the meter displays the ambient refrigerant level.

**START-UP**

**Step 1:** Having confirmed that the wiring is correct, apply power to the unit. The normal warm-up period is 3 minutes. However, since power has been off since the unit was tested at the factory, allow the unit to warm-up for a minimum of 30 minutes (6-8 hours is preferable).

**WARNING**

**THE SENSOR OPERATES AT 900° CELSIUS, 1650° FAHRENHEIT, AND 180 VOLTS. NEVER TOUCH THE SENSOR WHILE POWER IS APPLIED.**

**Step 2:** The PPM meter should be reading less than 5 ppm.

If the unit is reading 10 ppm or higher or has gone into the Leak Wait Mode or Alarm Mode, there is a likelihood that there is a leak present. A high reading may also result from the recent use of a chlorinated cleaning agent. Many industrial degreasers do use a chlorine based compounds. Examples are trichloroethylene and perchloroethylene based solvents or cleaners. If you are convinced that there is no leak, and that there are no other sources of halogen vapors in the room, contact SenTech.

**Step 3:** The trip point setting of the unit is written on the inside front cover of the unit. Make note of the setting.

**Step 4:** To check for proper operation of the Monitoring, Leak Wait, and Alarm modes, it is necessary to prepare a sample of the refrigerant gas being used.

**CAUTION**

**VERY HIGH CONCENTRATIONS OF REFRIGERANT CAN SIGNIFICANTLY SHORTEN SENSOR LIFE. NEVER SQUIRT PURE REFRIGERANT TOWARDS THE SENSOR OPENING.**

a) Gaseous refrigerants: Obtain a small plastic garbage bag (waste basket size is fine). Open the bag and “fluff” it so that it is full of air. Insert a refrigerant fill hose into the bag opening. Close the mouth of the bag around the hose. Crack the valve for a second or less so that a small squirt of refrigerant enters the bag. Keep in mind the monitor reads in parts per million and a tiny amount of gas will make a relatively high concentration sample. Pull out the hose, and hold the bag tightly closed.

b) Liquid refrigerants: Obtain a small plastic “Ziplock®” type food storage bag. Open the bag slightly and put in a few drops of liquid refrigerant. Flatten the bag so that there is little air and seal it as tightly as possible. Warm the bag to gasify the refrigerant. The bag will expand as the liquid evaporates, but the seal should be good enough to keep any gas from escaping.

**Step 5:** Test to see that Leak Wait and Alarm Mode are operating properly. We are going to use the refrigerant sample to simulate a concentration of refrigerant in the air that is reasonably higher than the trip point. **NOTE: THE MORE THE READING EXCEEDS THE TRIP POINT THE SHORTER LEAK WAIT TIME.**

a) Gaseous refrigerants: Holding the bag tightly closed, bring the bag to just under the filter inlet (upper right side opening). Carefully loosen your grip on the bag to allow some gas to escape, watching the meter as you do this. You should try and allow enough gas to leak to cause the meter to rise to 60 to 90 ppm. Precision is not possible, and the goal is to see the unit enter Leak Wait Mode and then Alarm Mode

b) Liquid refrigerants: Using a pin or paper clip, prick a hole in the bag. Hold the bag just under the filter inlet (upper right side opening). Squeeze the bag slightly and watch the meter. You should try and allow enough gas to leak to cause the meter to rise to 60 to 90 ppm. Precision is not possible, and the goal is to see the unit enter Leak Wait Mode and then Alarm Mode.

In either a) or b), there will be a five (5) second delay before the meter starts to react.

**Step 6:** The system should now be in Alarm Mode. Confirm that the alarm light is flashing and the analog meter is steadily reading a ppm level. Check that any optional horns, lights, or other devices are appropriately energized.

**Step 7:** Push reset to put the system back into Monitor Mode, and reconnect the pickup tube.

**Step 8:** Dispose of the gas samples in an appropriate manner.

**Step 9:** Fill out the CTS/Warranty card completely and return to SenTech. This is an important step and must not be overlooked.

**Step 10:** Store this manual in safe place so that it will be available for future reference.

Basic installation and start-up are now complete, and the unit is on line and monitoring.

**Case A:** Maximize early leak detection/tolerant of occasional false alarms

Background PPM	Trip Point PPM
less than 2	6.75
3 - 5	12.5
6 - 10	25

**Case B:** Keep false alarms to a minimum.

Background PPM	Trip Point PPM
less than 2	12.5
3 - 5	25
6 - 10	35

When you have decided on an appropriate trip point setting for your application, refer to Appendix A for instructions on how to set the trip point. Once you have reset the trip point, make a note of the new trip point setting, the date and your signature of the change on the trip point setting label inside cover of the unit. In addition, note this change on the CTS form. This information is essential for troubleshooting any future problems.

## FINE TUNING

### CAUTION

**R123 HAS AN AEL (ACCEPTABLE ENVIRONMENTAL LEVEL) OF 30 PPM. THE RECOMMENDED TRIP POINT SETTING IS 12 PPM. THE TRIP POINT SHOULD NOT BE SET ABOVE 30 PPM.**

The trip point is set, at the factory, for typical background conditions of 5 ppm or less. Under these conditions there is very little likelihood of random false alarms. However, the threshold for detecting small leaks is also higher than it might otherwise have to be. Conversely, even after eliminating any preexisting leaks, your background may be higher than typical for a variety of reasons. Under these conditions, the likelihood of random false alarms may be increased. Therefore, it may be desirable to fine tune the System 1000 trip point. If that is the case, follow the steps outlined below.

**Step 1:** For the next two weeks check and note the ppm reading daily or preferably 2 or 3 times per day. Vary the time(s) of day that you make the checks so that you can arrive at a reasonably accurate estimate of your typical peak background condition. If the reading steadily increases, you may have a developing leak which must be repaired before proceeding.

**Step 2:** Reset the trip point.

## PREVENTIVE MAINTENANCE

### Air Filters:

The only preventive maintenance that needs to be accomplished on a routine basis is to periodically clean or replace the cooling air inlet and outlet filters. Dirty filters will reduce cooling air flow and could shorten the life of the electronics. The cooling air filters should be cleaned at least once per quarter.

### 5 Micron Sensor Inlet Filter and Orifice:

At least once per quarter, compare the flowmeter reading to the initial flow noted on the decal on the inside of the door. If the flow has dropped by 100 cc's/min or more, either the orifice or the 5 micron filter or both have become partially blocked.

### Periodic Performance Check:

Once a week, push the reset pushbutton and check that the analog reading goes to zero and the system goes through the normal warmup procedure. After the unit is back on line, check that ambient ppm reading is in the normal range for your environment.

Once per quarter, go through steps 4 through 8 of the start up instructions.

# APPENDIX A

## TRIP POINT AND FUNCTION SWITCH SETTINGS

There are two 8-position dip (dual in-line package) switches on the main control board, see Appendix Diagram "A". Switch S1 is a function switch. Switch S2 is used to set the trip point for Alarm Mode.

### S1 Function Switch

#### Positions 1 through 7

These positions are used to set parameters for communicating to external devices and computers. If you have one of these options, refer to the instruction literature provided with the option for information on how to set the switches. If you are not using the external communications capabilities, you can ignore positions 1 to 7. They do not affect any other function.

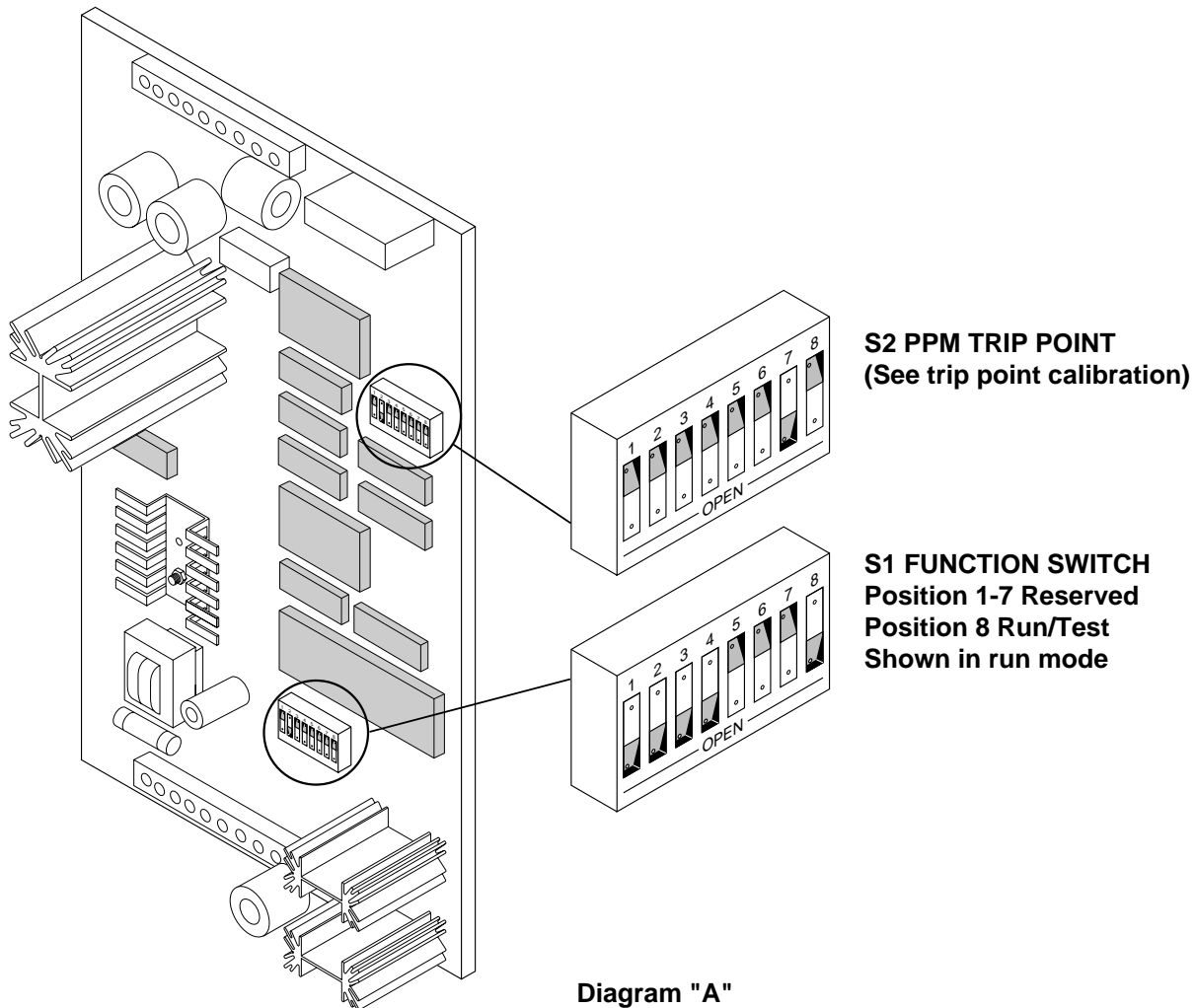
#### Position 8 Run/Test

Position 8 determines whether the unit is in Run Mode or Test Mode. Test mode is used for trouble shooting and maintenance. For normal operation the position 8 must be in run mode. Appendix Diagram "A" shows the switch in the run position. In the Test Mode, the Alarm Light is on continuously.

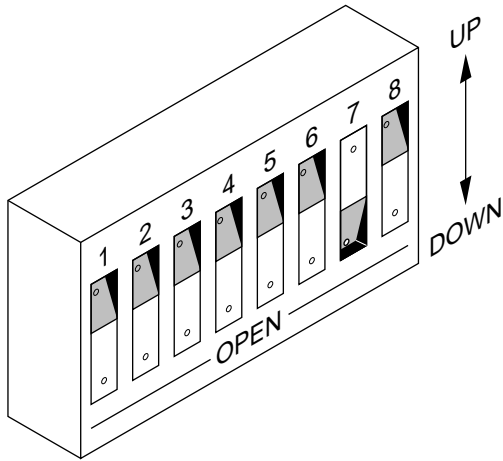
### S2 Trip Point

Switch 2 is used to set the trip Point, the ppm reading at which the unit will go into Alarm Mode. See the following page, Trip Point Settings displays how to set the switch for a variety of refrigerant levels. The switch has been preset at the factory. There is a label on the inside front cover of the unit with the value of the preset trip point. If the switch setting is changed, note this change on the label inside the front panel of the unit to indicate the new trip point, when it was set, and who set it. This can be a big help in troubleshooting should a problem develop.

The switch essentially provides the computer with an 8 bit binary fraction of the full scale of the unit. For example if full scale of the monitor is 100 ppm, setting position 8 will be a trip point of 50 or half of full scale. Position 7 is one fourth of full scale, and so on down to position 1 which is one two hundred and fifty-fifth of full scale. By combining switches, it is possible to get any trip point required. For ease of use, it is suggested that you use the chart provided.



## TRIP POINT SETTINGS 100 PPM FULL SCALE CALIBRATION

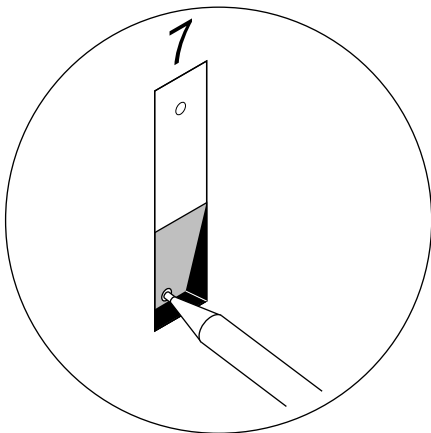


**FIGURE 1**  
**TRIP POINT SETTING**  
**@ PPM - 25**  
**(DIP SWITCH - 7)**

PPM	DIP SWITCH DOWN
*0	NONE
5	1,3,4
6.75	5
10	1,4,5
12.5	6
15	2,3,6
20	1,2,5,6
25	7
30	1,3,4,7
35	1,4,5,7
40	2,3,6,7
45	1,2,5,6,7
50	8
60	1,4,5,8
70	1,2,5,6,8
80	3,4,7,8
90	2,3,6,7,8
*100	1,2,3,4,5,6,7,8

Not recommended  
unless normal  
ambient very high

**\* DO NOT USE**



**FIGURE 2**  
**USE A PENCIL OR FINE TIP PIN**  
**TO SET THE SWITCHES**  
**(ILLUSTRATION SHOWS SWITCH #7 DOWN)**

**NOTE:**

For units with 0-1000 PPM full scale,  
multiply the PPM reading by 10.

Examples

<u>PPM</u>	<u>Dip Switch Down</u>
125	6
200	1,2,5,6
250	7

## Appendix B: SenTech Room Volume Considerations (English)

Normal industry practice is to think about refrigerant leaks in terms of pounds of refrigerant per unit time such as lbs/hr or ozs/yr. This is a natural and logical way of looking at it. The system monitors the amount of refrigerant present in the air in Parts Per Million (ppm) by volume of refrigerant molecules as compared to air molecules. In order to develop a relationship between the leak rate in weight per unit time and ppm reading of the monitor, there are a number of items that need to be considered and accounted for. These are:

1. Room Volume.
2. The relationship between refrigerant amount in weight compared to refrigerant volume at the temperature and pressure of the room.
3. The amount of time the refrigerant has been leaking.
4. The rate at which fresh air enters the room (stale air is exhausted).
5. The location of the monitor inlet relative to the leak, the air patterns of the room, and the rate at which the leaking refrigerant expands to fill the room.

For a given specific situation items 1 through 4 are either known, can be calculated, or can be estimated. Item 5 is virtually unknowable, therefore in all the formulas and sample calculations it is assumed that leaking refrigerant expands immediately to fill the room. This is a reasonable and conservative assumption on the basis that you have located the monitor following the recommendations outlined in the installation section. If you have followed those recommendations, the monitor should see a higher concentration sooner than the idealized formulas.

The equations have been developed for two cases. **Case I** is for a sealed room, no air turnover. **Case II** is for a room with a known turnover of air.

To be able to convert between a leak rate in cubic feet per hour to a leak rate in pounds per hour the molecular weight of the refrigerant needs to be known. If you know the molecular weight of the refrigerant, you can calculate the necessary conversion factors at normal atmospheric pressure and room temperature.

$$\frac{\text{Mol Wt(gms)}}{1(\text{mole})} \times \frac{1(\text{mole})}{22.4(\text{ltrs})} \times \frac{1(\text{pound})}{454(\text{gms})} \times \frac{28.32(\text{ltrs})}{1(\text{cuft})} \times \frac{273}{293} = \frac{\#}{\text{cuft}}$$

Substituting for R-22 which is 86.48 grams/mole, you get  $0.22 \frac{\#}{\text{cuft}}$ .

### Conversion Factors for Common Refrigerants

R-22	.22 #/cuft	4.46 cuft/#
R-12	.31 #/cuft	3.18 cuft/#
R-11	.36 #/cuft	2.80 cuft/#
R-502	.29 #/cuft	3.45 cuft/#
R-123	.41 #/cuft	2.41 cuft/#

### PPM READINGS AND LEAK RATE RELATIONSHIP DEFINITIONS:

- PPM = Monitor PPM reading or trip point PPM setting
- LR = Leak Rate of refrigerant in cubic feet per hour
- FA = Fresh Air into the room in cubic feet per hour
- VOL = Volume of the room in cubic feet
- t = Time in hours (There are 8760 hours in one year)
- R = Amount of refrigerant in the room in cubic feet
- LR<sub>min</sub> = Minimum leak rate that will reach a given PPM

#### Case I: Sealed Room

$$\text{PPM} = \frac{\text{LR} \times t \times 10^6}{\text{VOL}} \quad t = \frac{\text{PPM} \times \text{VOL} \times 10^{-6}}{\text{LR}}$$

$$R = \text{PPM} \times \text{VOL} \times 10^{-6}$$

#### Case II: Room with Air Changing

$$\text{PPM} = \frac{\text{LR}}{\text{FA}} \left(1 - e^{-\frac{\text{FA}}{\text{VOL}} t}\right) 10^6$$

$$t = \frac{\text{VOL}}{\text{FA}} \times \ln \left( \frac{\text{LR}}{\text{LR} - \text{PPM} \times \text{FA} \times 10^{-6}} \right)$$

$$\text{LR}_{\text{min}} = \text{PPM} \times \text{FA} \times 10^{-6}$$

**Sample Calculations (Assuming The room is 40 feet by 30 BY 10 feet = 12,000 cuft)**

#### Case I: Sealed Room

1. How much refrigerant is necessary to cause a 25 ppm reading ?

$$R = 25 \times 12000 \times 10^{-6} = .3 \text{ cuft}$$

If it is R-22: .3 cuft x .22 lb/cuft = .066 lbs

2. If the leak rate is 300 lbs./year of R-22, how long will it take to reach 25 ppm ?

$$\frac{300 \text{ lbs}}{\text{yr}} \times \frac{1 \text{ yr}}{8760 \text{ hr}} \times \frac{4.46 \text{ cuft}}{\text{lbs}} = .153 \text{ cuft/hr}$$

$$t = \frac{25 \times 12000 \times 10^{-6}}{.153} = 1.96 \text{ hrs}$$

#### Case II: Room with Air Changing

Assume the same room 12,000 cuft.

Assume fresh air at 100 cfm or 6000 cuft/hr (1 air changes in 2 hour).

1. What is the minimum leak that will reach 25 ppm ?

$$\text{LR}_{\text{min}} = 25 \times 6000 \times 10^{-6} = .15 \text{ cuft/hr}$$

for R-22: .15 cuft/hr x .22 lb./cuft = .033 lbs/hr or 289 lbs/yr

2. How long will it take to detect a leak of 500 lbs/yr of R-22?

$$500 \text{ lbs/yr} = .26 \text{ cuft/hr}$$

$$t = \frac{12000}{6000} \times \ln \left( \frac{.26}{.26 - 25 \times 6000 \times 10^{-6}} \right) = 1.72 \text{ hrs}$$

3. If the trip point is set at 10 ppm, what is the minimum leak rate of R-123 that will trigger the alarm ?

$$\text{LR}_{\text{min}} = 10 \times 6000 \times 10^{-6} = .06 \text{ cuft/hr}$$

for R-123: .06 x .41 lbs/ft = .0246 lbs/hr or 215 lbs/yr

4. How long will it take to detect a leak of 300 lbs/yr of R-123 ?

$$300 \text{ lbs/yr of R-123} = .0825 \text{ cuft/hr}$$

$$t = \frac{12000}{6000} \times \ln \left( \frac{.0825}{.0825 - 10 \times 6000 \times 10^{-6}} \right) = 2.6 \text{ hrs}$$

These numbers represent worst case conditons. With the monitor placed close to the potential leak points and on the "downwind" side of the air flow, the trip points are likely to be activated sooner.

## Appendix B: SenTech Room Volume Considerations (Metric)

Normal industry practice is to think about refrigerant leaks in terms of weight of refrigerant per unit time such as kg/hr or kg/yr. This is a natural and logical way of looking at it. The system monitors the amount of refrigerant present in the air in Parts Per Million (ppm) by volume of refrigerant per volume of air. In order to develop a relationship between the leak rate in weight per unit time and ppm reading of the monitor, there are a number of items that need to be considered and accounted for. These are:

1. Molecular weight of the refrigerant.
2. Density of the refrigerant at the temperature of the room.
3. Room volume.
4. The rate at which fresh air enters the room.
5. The location of the monitor inlet relative to the leak, the air patterns of the room, and the rate at which the leaking refrigerant expands to fill the room.

For a given specific situation items 1 through 4 are either known, or can be calculated. Item 5 is virtually unknowable, therefore in all the formulas and sample calculations it is assumed that leaking refrigerant expands immediately to fill the room. This is a reasonable and conservative assumption on the basis that you have located the monitor following the recommendations outlined in the installation section. If you have followed those recommendations, the monitor should see a higher concentration sooner than the idealized formulas.

The equations have been developed for two cases. **Case I** is for a sealed room, no air turnover. **Case II** is for a room with a known turnover of air.

To be able to convert between a leak rate in cubic meters per hour to a leak rate in kilograms per hour the density of the refrigerant must be known. At normal atmospheric pressure and room temperature.

$$\text{DENSITY (kg/m}^3\text{)} = \frac{\text{Mol Wt(gms)}}{22.4(\text{ltrs})} \times \frac{273}{293} \times \frac{1(\text{kg})}{1000(\text{gms})} \times \frac{1000(\text{ltrs})}{1(\text{m}^3)}$$

As an example for R-22, Mol Wt = 86.48 gm/mole.  
Therefore density = 3.59 kg/m<sup>3</sup>, or 0.28 m<sup>3</sup>/kg

### Conversion Factors for Common Refrigerants

R-22	3.59 kg/m <sup>3</sup>	0.28 m <sup>3</sup> /kg
R-12	4.96 kg/m <sup>3</sup>	0.20 m <sup>3</sup> /kg
R-11	5.76 kg/m <sup>3</sup>	0.17 m <sup>3</sup> /kg
R-502	4.64 kg/m <sup>3</sup>	0.21 m <sup>3</sup> /kg
R-123	6.56 kg/m <sup>3</sup>	0.15 m <sup>3</sup> /kg

### PPM READINGS AND LEAK RATE RELATIONSHIP DEFINITIONS:

- PPM = Monitor PPM reading or trip point PPM setting
- LR = Leak Rate of refrigerant in cubic meter per hour
- FA = Fresh Air into the room in cubic meter per hour
- VOL = Volume of the room in cubic meter
- t = Time in hours (There are 8760 hours in one year)
- R = Amount of refrigerant in the room in cubic meters
- LR<sub>min</sub> = Minimum leak rate that will reach a given PPM

#### Case I: Sealed Room

$$\text{PPM} = \frac{\text{LR} \times t \times 10^6}{\text{VOL}} \quad t = \frac{\text{PPM} \times \text{VOL} \times 10^{-6}}{\text{LR}}$$

$$R = \text{PPM} \times \text{VOL} \times 10^{-6}$$

#### Case II: Room with Air Changing

$$\text{PPM} = \frac{\text{LR}}{\text{FA}} (1 - e^{-\frac{\text{FA}}{\text{VOL}t}}) 10^6$$

$$t = \frac{\text{VOL}}{\text{FA}} \times \ln \left( \frac{\text{LR}}{\text{LR} - \text{PPM} \times \text{FA} \times 10^{-6}} \right)$$

$$\text{LR}_{\text{min}} = \text{PPM} \times \text{FA} \times 10^{-6}$$

### SAMPLE CALCULATIONS (ASSUMING THE ROOM IS 15 METERS BY 10 METERS BY 3 METERS = 450 CUBIC METERS)

#### Case I: Sealed Room

1. How much refrigerant is necessary to cause a 25 ppm reading ?  
 $R = 25 \times 450 \times 10 = .0011$  cubic meter  
 If it is R-22:  
 Amount of refrigerant = .0011 m<sup>3</sup> x 3.59 kg/m<sup>3</sup> = .004 kg
2. If the leak rate is 150 kg/year of R-22, how long will it take to reach 25 ppm ?  

$$\frac{150 \text{ kg}}{\text{yr}} \times \frac{1 \text{ yr}}{8760 \text{ hr}} \times \frac{.28 \text{ m}^3}{\text{kg}} = 0.0048 \text{ m}^3/\text{hr}$$

$$t = \frac{25 \times 450 \times 10}{0.0048} = 2.35 \text{ hrs.}$$

#### Case II: Room with Air Changing

- Assume the same room (450 m<sup>3</sup>).  
Assume fresh air at 225 m<sup>3</sup>/hr (1 air changes in 2 hour).
1. What is the minimum leak that will reach 25 ppm ?  
 $\text{LR}_{\text{min}} = 25 \times 225 \times 10 = 0.0056 \text{ m}^3/\text{hr}$   
 for R-22:  
 $0.0056 \text{ m}^3/\text{hr} \times 3.59 \text{ kg/m}^3 = 0.02 \text{ kg/hr OR } 175 \text{ kg/yr}$
  2. How long will it take to detect a leak of 200 kg/yr of R-22?  
 $200 \text{ kg/yr} = 0.023 \text{ kg/hr}$   

$$t = \frac{450}{225} \times \ln \left( \frac{.023}{.023 - 25 \times 225 \times 10^{-6}} \right) = 4.0 \text{ hrs}$$
  3. If the trip point is set at 10 ppm, what is the minimum leak rate of R-123 that will trigger the alarm ?  
 $\text{LR}_{\text{min}} = 10 \times 225 \times 10 = .00225 \text{ m}^3/\text{hr}$   
 for R-123: .00225 x 6.56 kg/m<sup>3</sup> = .0148 kg/hr OR 130 kg/yr
  4. How long will it take to detect a leak of 150 kg/yr of R-123 ?  
 $150 \text{ kg/yr of R-123} = .0026 \text{ m}^3/\text{hr}$   

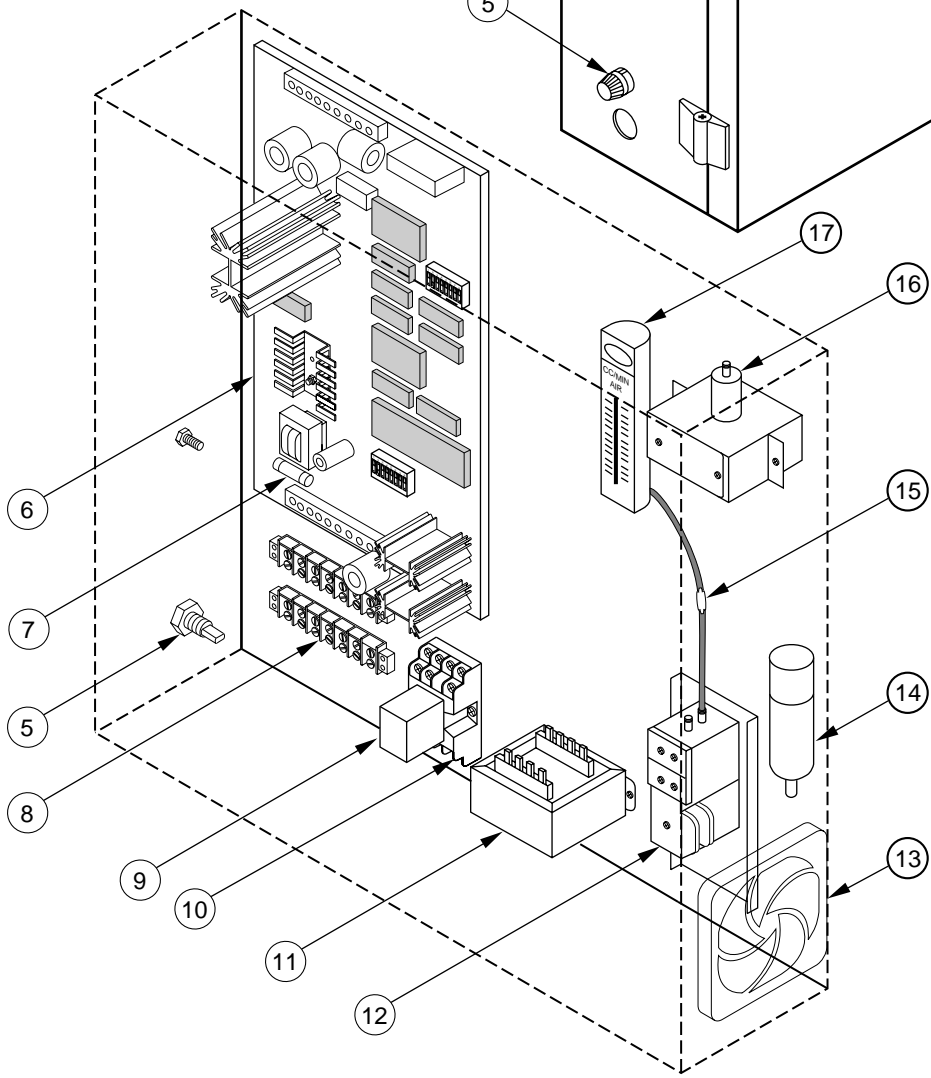
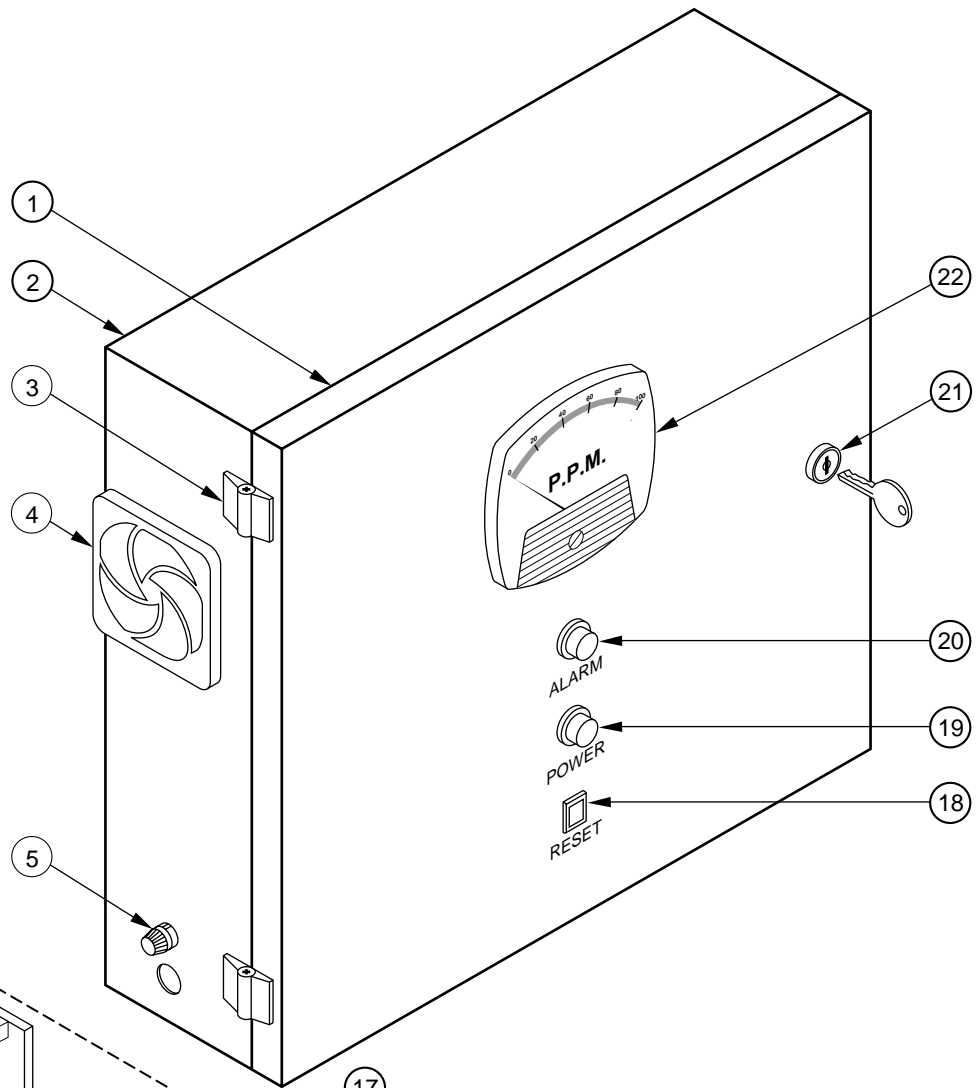
$$t = \frac{450}{225} \times \ln \left( \frac{.0026}{.0026 - 10 \times 225 \times 10^{-6}} \right) = 4.0 \text{ hrs}$$

These numbers represent worst case conditons. With the monitor placed close to the potential leak points and on the "downwind" side of the air flow, the trip points are likely to be activated sooner.

**SenTech  
SYSTEM 1000  
MODEL 1030**

**EXPLODED VIEW  
&  
PARTS LIST**

- 1. Lid, Finished .....400157
- 2. Box, Finished .....400154
- 3. Hinge (2) .....410050
- 4. Fan Guard/Filter .....410017  
Filter Replacement .....410018
- 5. Main Power Fuse .....410034  
Main Power Fuse Holder 410033
- 6. Control Board\* .....410037
- 7. Filament Current Fuse ....410233
- 8. Connector, 7 position .....410041
- 9. Relay, Alarm .....410028
- 10. Relay Socket .....410040
- 11. Power Transformer .....410039
- 12. Diaphragm Pump .....410224
- 13. Fan Guard/Filter .....410017  
Filter Replacement .....410018



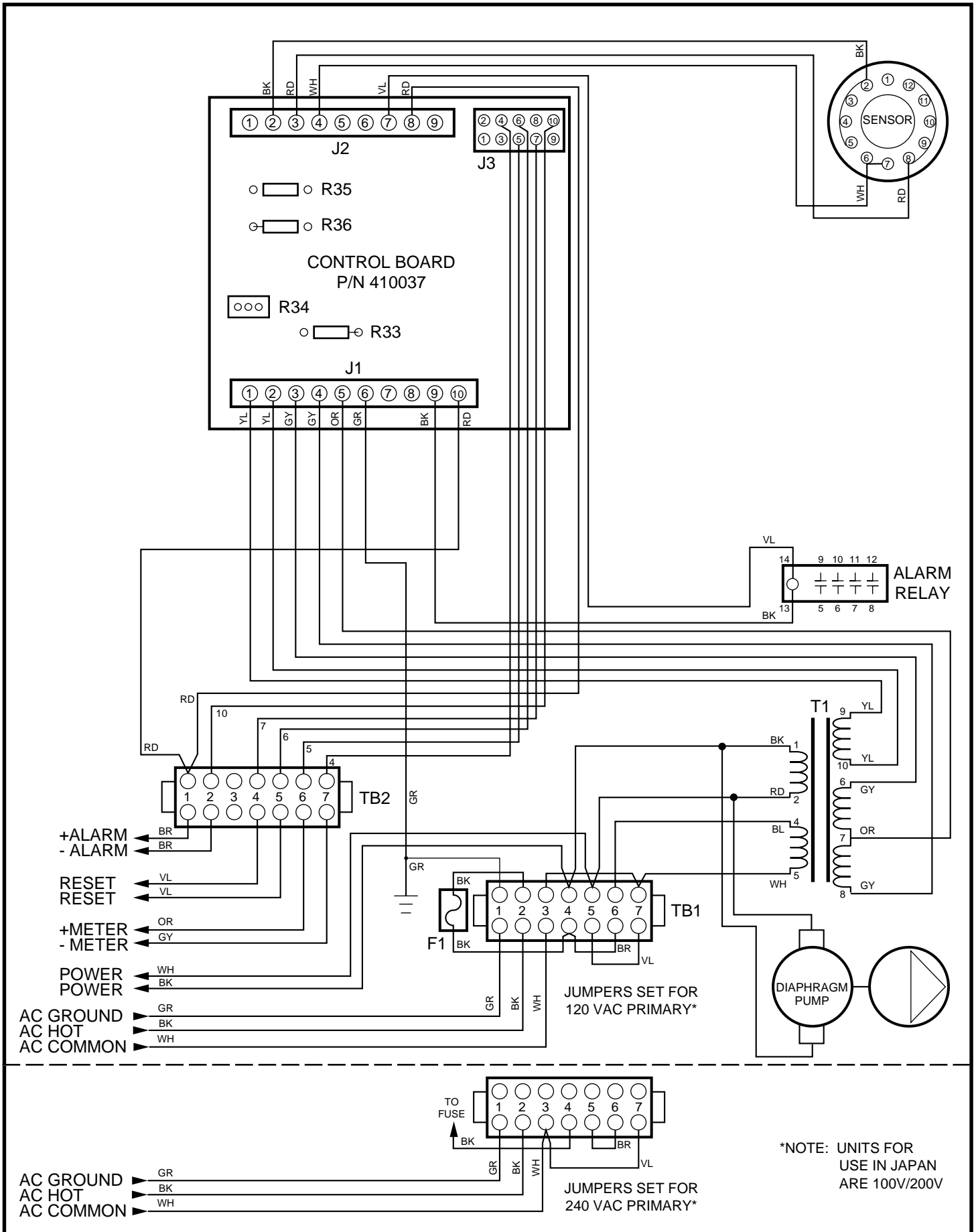
- 14. 5 Micron Filter ..... 410122
- 15. Orifice .....410136
- 16. Sensor\* .....410027
- 17. Flowmeter .....410121
- 18. Switch, Panel Reset .....410009
- 19. Lamp, Panel Power .....410008
- 20. Lamp, Panel Alarm .....410007
- 21. Key Lock Assembly .....410006
- 22. Meter, Analog .....410010

**OPTIONAL EQUIPMENT**

- Alarm, Visual Strobe ..... 410061
- Alarm, Audible Horn .....410062
- Alarm, Combination  
Horn/Strobe .....410036

\* Replacement of any of these parts requires recalibration. Return to the factory for repair.

# SenTech SYSTEM 1000, MODEL 1030 WIRING DIAGRAM



# Troubleshooting Guide

Before starting, refamiliarize yourself with the START-UP section of the manual. Depending on the problem, you may need to prepare a sample of refrigerant to use in testing. You should also check the appendix on setting the trip point and function switches. Certain of these tests will require the use of a volt/ohm multimeter.

If you determine that there is a problem in either the sensor, the main control board, or the bridge board, the unit will have to be returned to the factory for repair and recalibration

Symptom	Remedy
<b>1. No power light.</b>	<ol style="list-style-type: none"><li>1. Check fuse fl and replace if failed.</li><li>2. Check incoming AC Power at TB1-2 and TB1-3 120 (240) volts AC.</li></ol>
<b>2. Flowmeter reading 0 cc/min.</b>	<ol style="list-style-type: none"><li>1. Check that the diaphragm pump is operating and replace if it has failed.</li><li>2. Check the the tubing from the diaphragm pump output to the flowmeter and make certain that it has not come loose at any point.</li><li>3. If the tubing run seems continuous with no obvious blockages or kinks, follow the trouble shooting procedures for low flow.</li></ol>
<b>3. Flowmeter reading less than the initial reading by more than 100 cc/min.</b>	<ol style="list-style-type: none"><li>1. Either the orifice or the 5 micron filter or both have become partially or completely blocked blocked.<ol style="list-style-type: none"><li>a). Unscrew the plastic bottle on the 5 micron filter and recheck the flow. If the flow has returned to normal, replace the 5 micron filter element.</li><li>b). If the flow remains low, remove the orifice and clean it by blowing compressed air through it. Recheck the flow. If it is not back to normal, replace the orifice. Note, the orifice must be replaced with the arrow pointing towards the flowmeter.</li></ol></li></ol>
<b>4. Failure to detect a leak/ suspected low sensitivity.</b>	<ol style="list-style-type: none"><li>1. Alarm light is on continuously, alarm relay did not energize. The system is in test mode, see Appendix A. Set function switch S1 to RUN and push the reset button to go back into normal operation.</li><li>2. Alarm light is flashing indicating an alarm, but external alarm devices (horns, lights, etc) not actuated.<ol style="list-style-type: none"><li>a). Check for 12 volts DC at the alarm relay coil between p13 and p14. If there is no voltage, the control board has failed*.</li><li>b). If voltage is present, check that the relay is energized by testing for continuity at an unused set of normally open contacts (see diagram on the inside front cover of the enclosure). If the relay is not energized, replace it.</li><li>c). If the relay is energized, check the wiring to the external devices, and check the devices themselves for proper operation.</li></ol></li><li>3. Sensor filament circuit check. Feel the top of the Model 1030 enclosure (just above the sensor area). If it feels warm to the touch, it indicates the tube is getting current. A double check is to touch the large heatsink at the upper left hand side of the control board. It also should be warm to the touch. If the tube is getting current, go on to item 4. If the tube is not getting current:<ol style="list-style-type: none"><li>a). Check the fuse on lower left hand of the control board. If the fuse is blown, replace it with a 7 amp 250 volt slo blo.</li><li>b). Check that the tube is well seated in the socket.</li><li>c). Check and tighten the connections at pins 2, 3, and 4 of J2, the connector at the top of the main control board.</li><li>d). Check for 10 volts AC between J1-1 and J1-2, the connector at the bottom of the main control board. If there is no voltage, or it is substantially below 10 volts, replace the main transformer</li></ol></li></ol>

\*A failure in the control board or sensor require the unit be returned to the factory for repair and recalibration.

---

## Symptom

## Remedy

---

### 4. continued

If a) through d) check out OK, the main control board or sensor has failed\*.

4. Check the trip point setting of the unit to make certain that it has not been set too high. Typical trip point settings should be 30 PPM or less. (see Appendix A). If the trip point is too high, reset it and repeat steps 3 through 6 of the start-up procedure to confirm proper operation.
5. If steps 1 through 4 have not uncovered the problem, repeat steps 3 through 6 of the start-up procedure. If the system does not respond properly, there has been a failure in the main control board or sensor\*.
6. If all of the checks indicate the unit is operating properly, yet it is still believed that a leak was not detected by the system. Review the Location section of the installation procedure. It may be that the unit is not located in an appropriate position.

### 5. System has gone into alarm and it is believed there is no leak.

1. Depress the reset switch, and wait for completion of the warm-up period. If the system does not go into alarm, repeat steps 3 through 6 of the start-up procedure. If the unit appears to operate normally, there may have been a transient phenomenon that caused the alarm. Some examples are:
  - a). Someone using a halogen based degreaser such as trichloroethylene near the system.
  - b). A leaky purge that caused a transient increase in the refrigerant level.

Monitor the system closely for the next several weeks to see if it continues to operate normally.

2. If after going through the warm-up cycle, the system goes into alarm yet the meter reading indicates a very low PPM. Check that the trip point setting has not been changed to 0 PPM or a very low value that is likely to be below ambient conditions (see Appendix A). If that is the case, reset the trip point to the appropriate value for your environment, and recheck as in step 1 above.
3. If after going through the warm-up cycle, the system goes into alarm and the meter reading is above the trip point, set function switch S1 in the test mode (see appendix A), and reset the system. In test mode, the alarm circuitry is bypassed and the unit continuously reads ambient PPM level.

Check that the RUN/CAL switch on the control board is in the RUN position (to the right). If it is in the CAL position, switch to RUN and wait several minutes to see if the PPM decreases to a normal reading. If it is in the RUN position, flip the switch back and forth several times to make certain there is not a contact problem. Leave it in the RUN position, and again wait several minutes to see if the system returns to a normal reading. If the system appears to be working, put the function switch S1 back into the run mode, and press the reset push-button. After the warm-up period, go through steps 3 to 6 of the setup procedure to confirm normal operation.

4. If the RUN/CAL switch test does not resolve the problem, there are three likely possibilities:
  - a). There is in fact a leak in the refrigerant system.
  - b). There is a high ambient level of a halogen based hydrocarbon. This may be the result of chemicals stored in the room (such as a leaking refrigerant cylinder).
  - c). The unit has failed.

There is one inconvenient but sure way of testing for system failure. Disconnect the unit and move it to another area of the building or take it outdoors and supply power to the unit. If you still have a high reading, it is likely there has been a failure in the control board or sensor\*.

\*A failure in the control board or sensor require the unit be returned to the factory for repair and recalibration.



# GLOBAL MONITORING OF HALOGEN GASES

**SenTech**, gives the following as its complete Limited Warranty Statement:

## **SenTech Manufacturer's Limited Warranty**

**SenTech** warrants to the original purchaser-user that its equipment, as originally supplied, is free from defects in materials and workmanship and will perform adequately under normal use and service, subject to the following conditions and limits:

If the equipment or any part or parts thereof prove to be defective in normal use, then such item or parts will be repaired or replaced at the option of **SenTech** by **SenTech**, provided that notice of such defect is given by original purchaser-user to **SenTech** within one (1) year from the date of original installation of the equipment.

Warranty is made on condition that such original purchaser-user has returned to **SenTech** the warranty registration form applicable to the equipment, duly and fully completed, within thirty (30) days of the date of purchase by the original purchaser-user.

**SenTech's** obligation under this warranty is limited exclusively to replacing without charge, or to repairing, at **SenTech's** option, upon return to Indianapolis, Indiana, transportation charges prepaid, any part or parts that shall be found to be defective in material or workmanship during the warranty period. Charges for labor (except for labor performed by **SenTech** factory for repairing defective parts) are not covered and these, plus all other costs and expenses for transportation, insurance, etc., shall be paid for by the Warrantee. If, upon inspection by **SenTech** or its Authorized Service Representative, it is determined that the equipment has not been used in an appropriate manner as described in the **SenTech** Operator's Manual or has been subject to misuse, alteration, accident, damage during transit or delivery, or that such part is from a machine on which the serial number has been altered or removed, then this warranty is void and of no further force or effect. All decisions regarding the existence of defects in material or workmanship or other causes shall be made by **SenTech's** Factory Representative and shall be final and binding upon the parties. Returns shall only be made upon the prior written authorization thereof by **SenTech**.

THE FOREGOING LIMITED WARRANTY IS EXPRESSLY MADE IN LIEU OF ANY AND ALL OTHER WARRANTIES, EXPRESS OR IMPLIED, INCLUDING WITHOUT LIMITATION ANY IMPLIED WARRANTY OF MERCHANTABILITY OR FITNESS FOR A PARTICULAR PURPOSE.

The foregoing limited warranty shall not be enlarged or affected by, and no liability or obligation shall arise from, **SenTech's** rendering of technical or other advice, or service, in connection with any of its equipment or parts. Employees, agents, distributors, retailers, and sales representatives are not authorized to make warranties. Oral or written statements made may them do not constitute warranties and shall not be relied upon.

REPLACEMENT OR REPAIR OF DEFECTIVE EQUIPMENT OR PARTS AS PROVIDED ABOVE IS THE ORIGINAL PURCHASER-USER'S SOLE AND EXCLUSIVE REMEDY FOR CONTRACT, WARRANTY, NEGLIGENCE, TORT OR STRICT LIABILITY CLAIMS FOR ANY LOSS, DAMAGE OR EXPENSE ARISING OR ALLEGED TO ARISE OUT OF THE DESIGN, MANUFACTURE, SALE, DELIVERY OR USE OF SUCH EQUIPMENT AND/OR PARTS. IN NO EVENT SHALL SENTECH BE LIABLE FOR ANY AMOUNT IN EXCESS OF THE PURCHASE PRICE OF THE EQUIPMENT, OR FOR LOSS OF USE OR PROFITS, LOSS OF BUSINESS INTERRUPTION, ATTORNEY'S FEES, OR CONSEQUENTIAL, CONTINGENT, INCIDENTAL OR SPECIAL DAMAGES CAUSED OR ALLEGED TO CAUSED IN WHOLE OR IN PART BY THE NEGLIGENCE, TORT, STRICT LIABILITY, BREACH OF CONTRACT, BREACH OF WARRANTY, OR OTHER BREACH OF DUTY OF OR BY SENTECH.

**SenTech**  
5745 Progress Road  
Indianapolis, Indiana 46241

**THIS LIMITED WARRANTY IS NOT TRANSFERABLE.**

## **Warranty Information**

---

Remove the Check Test Start (CTS) form from the pocket of this manual and fill it out in its entirety. Return the original (top) copy to SenTech by folding as instructed on the reverse of copy. Dealer/Distributor retain second copy and Owner/Operator retain third copy.

## **Replacement Parts**

---

When ordering replacement parts, specify the part numbers, give the description of the part, the model number and the serial number of the machine.

## **Parts Order Procedure**

---

Always order parts from your SenTech dealer. If for some reason you cannot contact your dealer, you may order directly from the factory. Be sure to use the following order procedure:

1. Order on your purchase order letterhead.
2. Specify shipping instructions. If any order is received without specific shipping instructions, the order will be shipped best way.
3. Indicate the quantity desired, the part number, and the part description.
4. Always indicate the model number and the serial number of the machine for which the part is being ordered. In the back of this manual is an exploded view drawing and parts list of your SenTech machine. This will aid you in ordering parts.
5. Regular mailed orders normally take three (3) days to process and ship.
6. All prices are subject to change without notice.
7. Parts Terms: All parts will be sent c.o.d. unless previous billing arrangements have been made. Customer is responsible for all freight and c.o.d. charges.
8. All shipments are made f.o.b. Indianapolis. By acceptance of a package, the carrier assumes liability for its deliveries to the customer in good condition. If a package is lost or damaged, immediately file a claim with the carrier, not SenTech.

## **Parts Return Procedure**

---

1. No warranty parts shall be returned to SenTech without written authorization from the factory parts department.
2. When any part is returned to SenTech for any reason, such part must be properly identified.
3. Parts returned without proper identification will be kept for a reasonable period of time and disposed of as seen fit. In such cases, no credit will be issued.
4. Nondefective parts will be returned to the customer at the customer's expense.
5. If a letter is written pertaining to any refund part, this letter should be attached to the package containing the part.
6. All correspondence pertaining to parts must be directed to the SenTech Parts Department at:  
  

**SenTech**  
**5745 Progress Road**  
**Indianapolis, Indiana 46241**
7. All parts are sold f.o.b. factory.
8. Parts returned "collect" will be refused by our shipping department.



P/N 400140  
032795  
Rev. A