

ENVIRONMENTAL SYSTEM 2000
MODEL 2004, 2008, & 2016 (Rev. A)
OPERATION MANUAL

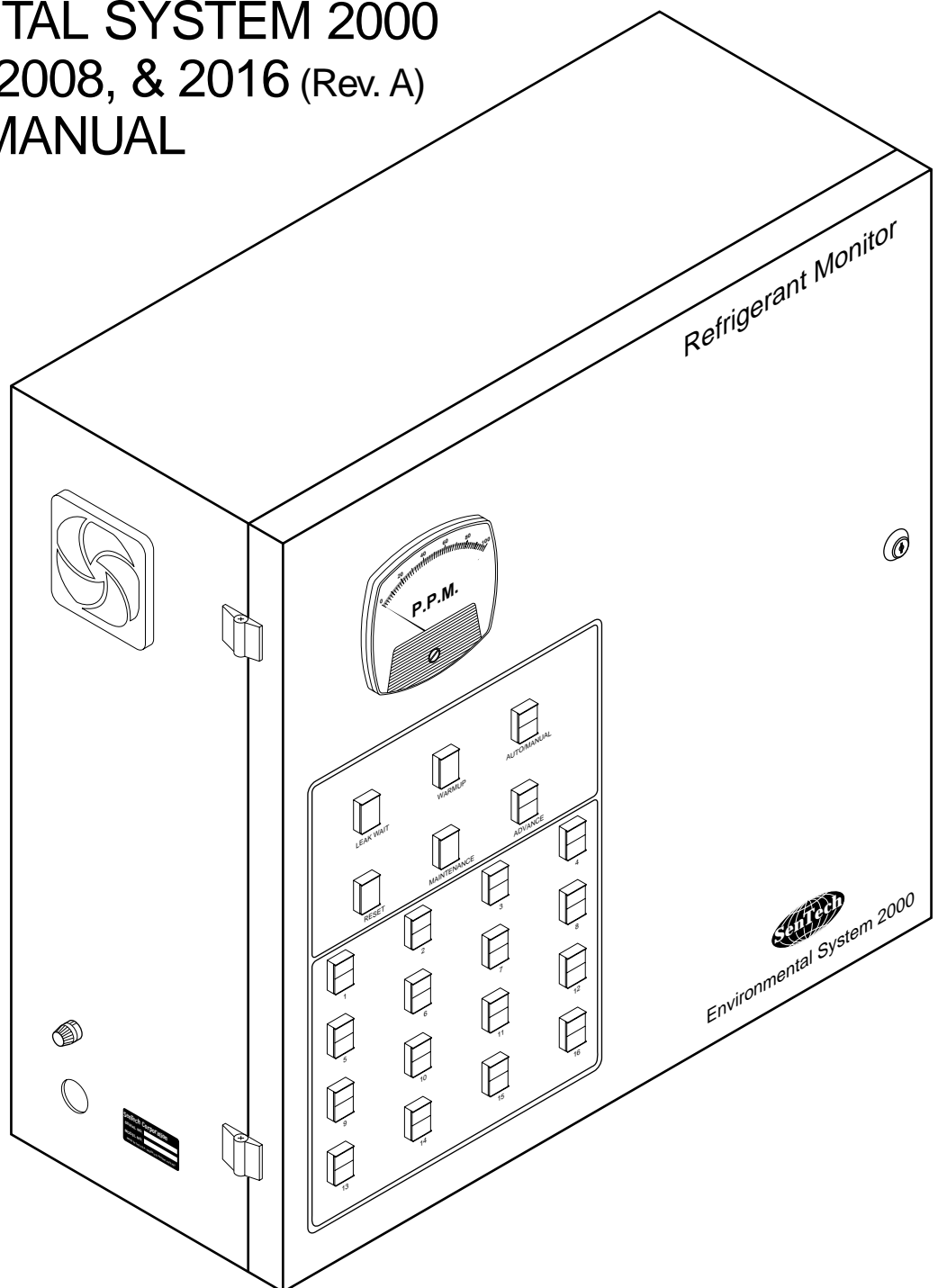

SenTech Corporation
5745 Progress Road
Indianapolis, Indiana 46241
PH: 317-248-1988
FAX: 317-248-2014

Distributor Name: _____

Address: _____

Phone: _____

Date of Installation: _____

Model Number: _____ Serial Number: _____

Installer/Service Technician: _____

WARRANTY INFORMATION: Remove the Check Test Start (CTS) form from the pocket of this manual and fill it out in its entirety. Return the original (top) copy to SenTech by folding as instructed on the reverse of copy. Dealer/Distributor retain second copy and Owner/Operator retain third copy.

IMPORTANT

TO VALIDATE WARRANTY, THE CTS FORM MUST BE COMPLETED AND RETURNED TO THE FACTORY WITHIN 30 DAYS OF INSTALLATION.

Note: The Check Test Start function should be performed by a qualified individual.

Table of Contents

INTRODUCTION/OVERVIEW	1
INSTALLATION	2
Location	2
Material Requirements	2
Mounting	2
Tubing Installation	2
Zone Selection	2
Installation Layout	3
Primary Power Wiring	4
OPTIONAL CONNECTIONS	4
OPERATIONS	5
Automatic	5
Manual	5
START-UP	6
FINE TUNING	8
PERIODIC PERFORMANCE CHECKS	9
PREVENTIVE MAINTENANCE CHECKS	9
MAINTENANCE & TROUBLESHOOTING	9
PNEUMATIC DIAGRAM & PARTS LIST	10
PROGRAMMABLE LOGIC CONTROL (PLC)	11
PLC Input/Output Chart	13
APPENDIX A	16
Trip Point & Function Switch Settings	16
Trip Point Setting/Calibration	17
APPENDIX B (Room Volume Considerations)	18
EXPLODED VIEW & PARTS LIST	20
TROUBLE SHOOTING GUIDE	22
CALIBRATION PROCEDURE	25
WIRING DIAGRAM	28
WARRANTY	29
PARTS	30

Illustrations

Fig. 1 System 2000 Block Diagram	1
Fig. 2 TBDC Terminal Board	2
Fig. 3 Primary Power Wiring	4
Fig. 4 Customer Connections	4
Fig. 5 Control Panel	6
Fig. 6 Pneumatic Subsystem Schematic	10
Fig. 7 Sensor Power Circuit	14
Fig. 8 Electronics Digital Control	14

Model 2000 Specifications	
Size:	24" X 24" X 8" (61 cm X 61 cm X 20.3 cm)
Weight:	70 lbs (31.8 kgs)
Power:	120 Volt, 60 Hz (250 Watt) 240 Volt, 50 Hz (250 Watt)
Temperature:	32°- 125° Fahrenheit (0°- 50° Centigrade)
Range:	0 - 100 P.P.M. Standard 0 - 1000 P.P.M. (for HFC's)
Tube Length:	0 - 500 ft (150 meters) maximum
Trip Point:	0 - 100% of FS
Zones:	Model 2004 - 1 to 4 (jumper selectable) Model 2008 - 1 to 8 (jumper selectable) Model 2016 - 1 to 16 (jumper selectable)
Sample Time:	One (1) minute per zone selected
Leak Wait:	Varies from seven (7) seconds to three (3) minutes depending on refrigerant concentration
Alarm Output:	Alarm Relay - Four (4) form C contacts rated 5 Amps maximum

INTRODUCTION/OVERVIEW

The SenTech Environmental System 2000 provides an early warning of developing refrigerant leaks. The unit sequentially samples ambient air in each active zone and measures the amount of halogen based refrigerant gases in the air sample. When the proportion of halogens present in a zone exceeds a trip point, the system goes into Alarm Mode notifying the user. By discovering the existence of a leak before the refrigerant loss has become great enough to be evident from a loss in equipment performance, the potential refrigerant loss is reduced saving money and helping protect the environment.

Basic Concept

Refer to the System 2000 Block Diagram (Fig. 1). Tubing from each area to be monitored is connected to the inlet manifold/valve assembly. The PLC (programmable logic controller) sequentially energizes the solenoid valves for each zone. The vacuum pump draws air from the selected zone and delivers it to the air sampling subsystem. The air sampling system delivers a controlled portion of the sample air to the sensor and exhausts the remainder. The system uses, an industry proven reliable halogen gas sensor.

The sample air flows across a heating element in the sensor which ionizes any halogen molecules present. The ionized halogens cause a current to flow which is proportional to the amount of ions present. The microprocessor controlled sensor electronics measures the current and provides an output reading of the concentration in ppm (parts per million).

More critically, it compares the ppm level to a preset trip point. When the trip point is exceeded, the sensor electronics report an Alarm condition to the PLC.

When the PLC receives an alarm signal, it enters Alarm Mode. In Alarm Mode, the Alarm light for that zone starts to flash, the Alarm relay is energized, and the sensor is deactivated to protect it from damage. The unit switches to the next zone and after a warm-up cycle, continues to monitor the remaining zones.

Sensitivity

The system is sensitive in varying amounts to all of the normal halogen based refrigerants, that is those molecules that contain either fluorine, chlorine, or both. Because of the variation in sensitivity each unit is calibrated at the factory for the specific refrigerant it is to monitor. In the event no refrigerant has been specified, it is calibrated for R22. When appropriately calibrated the System 2000 can sense concentrations as low as 1 ppm (10-20 PPM for HFC's).

There is no direct relationship between the amount of refrigerant leaking and the concentration level being measured. The size of the zone, the location of the monitor inlet tubing relative to the leak point, and the air pattern, all will affect the actual concentration at each zone. However, by judicious location of the inlet points (see installation section) and maintaining the trip point at a level not too far above the ambient, leaks should be detected substantially before they otherwise would be noticed. Refer to Appendix B for a detailed discussion of room size considerations.

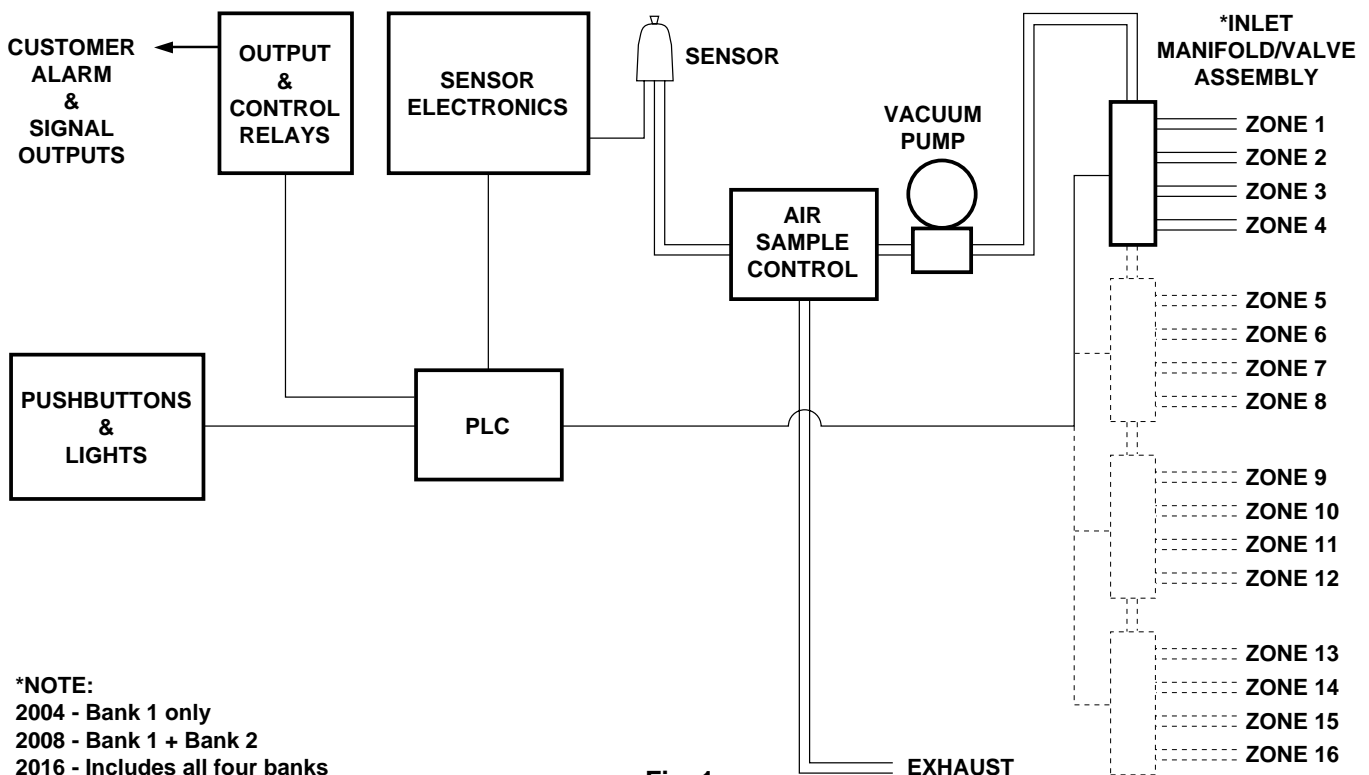

Fig. 1
System 2000 Block Diagram

INSTALLATION

Location

Since the sensor measures the concentration of refrigerant in air, each zone inlet tube should be mounted where it is most likely to sense leaking refrigerant. The criteria to consider in selecting the locations include:

- * As close to the area of potential leaks as possible. On the "downstream" side of the air flow pattern in the room.
- * Since refrigerants are typically heavier than air, lower is generally better than higher.
- * The control unit should be located such that the farthest pickup point will require no more than 500 feet (150 meters) of tubing.

CAUTION

MOISTURE CAN DAMAGE THE SENSOR. PICKUP POINTS MUST BE LOCATED AND PROTECTED WHERE NECESSARY TO PREVENT WATER FROM ENTERING THE SYSTEM.

Material Required (See the Installation Layout)

Packed within the System 2000 are the following items:

1. Instruction manual.
2. Schematic wiring diagram.
3. The sensor container which is packed with desiccant to keep it moisture free during storage and shipment.
4. The CTS/Warranty card which is to be completed and returned after start-up.
5. The coarse tube end filters.

Mounting

Drill the necessary holes and mount the unit. Carefully remove the packing material that protects the pneumatic components. Unpack the sensor and carefully insert the pin end of the sensor into the tubing that comes from the flowmeter. Insert the sensor into its socket. Make certain that the sensor is well seated. Make certain that the tubing is not kinked.

Tubing Installation

Install 3/8 inch (100 mm) plastic tubing from each zone pickup point to the zone inlet fittings on the right hand side of the control unit. Start with zone 1, the upper left hand fitting, and continue in sequence until the tubing for each zone is installed. Install the coarse filters at the pickup end of each tube. Mount the optional inline filter/separator assemblies in series with the tubing for those zones that are Particularly dirty and/or where there is any risk that water can enter the system. It is recommended that these units be mounted at a convenient point close to the pickup end of the tube run.

Zone Selection

The System 2000 allows you to select the number of zones to be monitored. For example, if the system Purchased is a 2008 (8 zone model) and you plan on monitoring only 6 zones, zones 7 and 8 can be disabled and will be bypassed by the control. Zones 1 through 6 will be the active zones.

It is necessary to inform the control of the number of zones selected. Refer to Terminal Board TBDC (Fig. 2) and the Zone Selection Chart. Selecting the number of zones is accomplished by installing jumpers between the appropriate terminals and +24 Volts dc. The first four positions on the terminal board are designated AZA, AZB, AZC, and AZD. Positions 5 and 6 are +24 Volts position 7 is the common side of the 24 Volts. Chart 1 shows the locations that require jumpers for the number of zones desired.

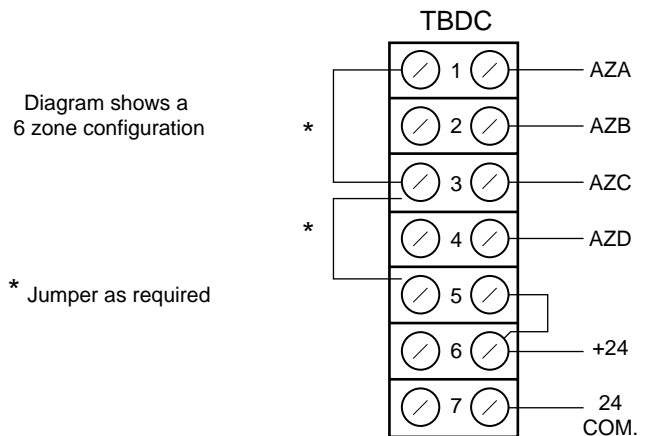
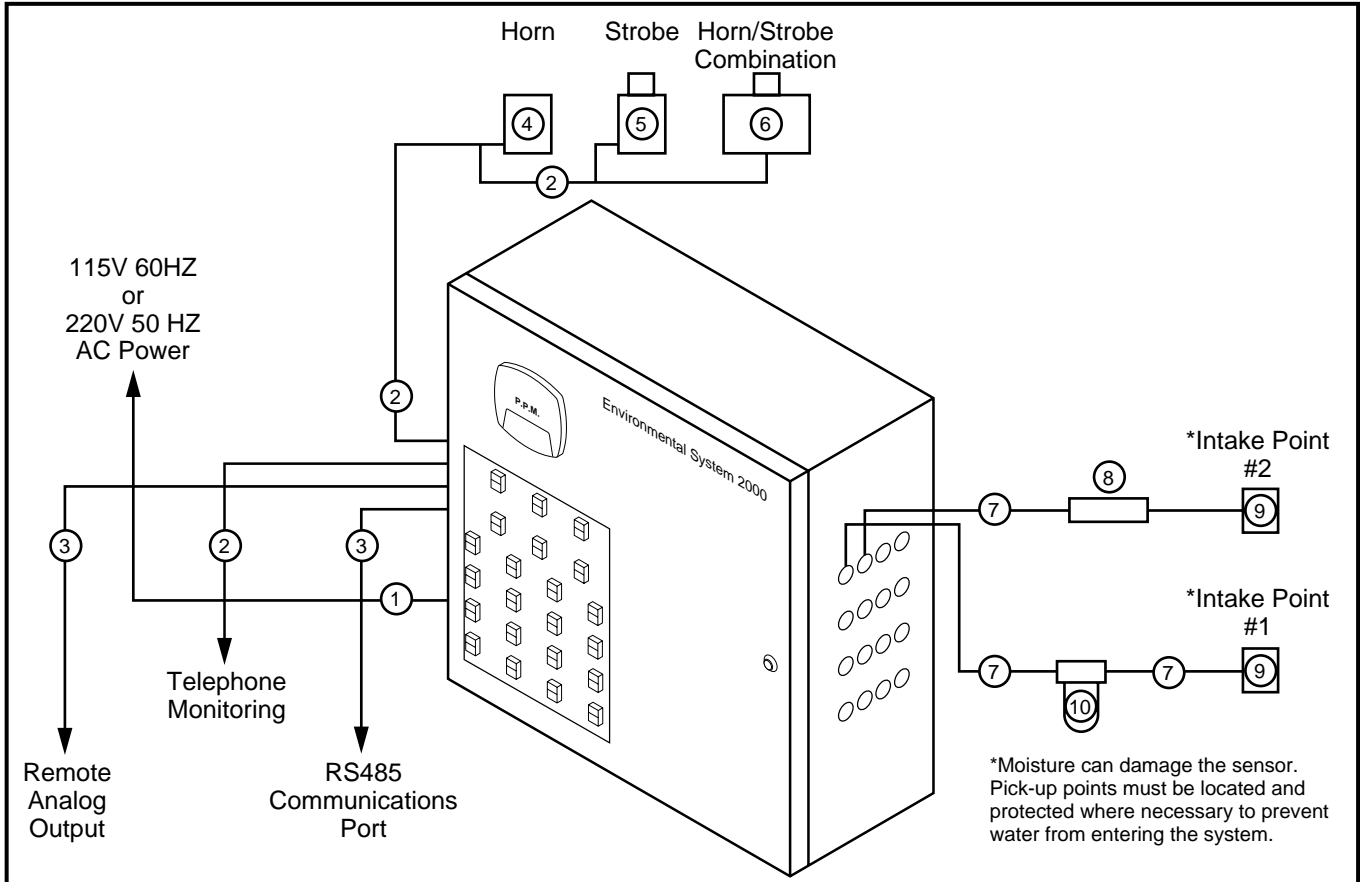

Fig. 2
Terminal Board TBDC

ZONE SELECTION CHART				
Zones Allowed	AZA	AZB	AZC	AZD
zero	(Not Allowed)			
one	open	open	open	open
two	24	open	open	open
three	open	24	open	open
four	24	24	open	open
five	open	open	24	open
six	24	open	24	open
seven	open	24	24	open
eight	24	24	24	open
nine	open	open	open	24
ten	24	open	open	24
eleven	open	24	open	24
twelve	24	24	open	24
thirteen	open	open	24	24
fourteen	24	open	24	24
fifteen	open	24	24	24
sixteen	24	24	24	24

Note: Open means no jumper, 24 means jumper to 24 Volt dc (position 5 or 6 of TBDC).

SenTech System 2000 Installation Layout



Item	Description	Required	Supplied with Unit	Supplied by Customer	Optional	Available from SenTech	Comments
1	16 Gauge, 3 Conductor Cable	yes	no	yes		no	
2	18 or 22 Gauge, 2 Conductor Cable	no			yes	no	Required for horn, strobe or combination
3	2 Conductor Twisted Pair Shielded Cable	no			yes	no	Required for remote analog output or RS485 communication
4	Horn	no			yes	yes	
5	Strobe Light	no			yes	yes	
6	Combination Horn and Strobe	no			yes	yes	
7	3/8" OD X 1/4" ID (10 mm OD X 7 mm ID) Plastic Tubing (recommend flame retardant, smoke resistant)	yes	no			yes	Available in 500 foot (150 m) reels
8	3/8" Tube Union				yes	yes	May be required to optimize tubing usage
9	Coarse Filter	yes	yes				For mounting at the end of the tubing
10	In-Line Filter/Separator Assembly	no			yes	yes	Recommended for particularly dirty environments and/or where there is any risk that water could enter the system

For the six zone example, Position 1-AZA should be jumpered to position 3-AZC, and position 3-AZC jumpered to position 5-24 Volt dc. Positions 2 and 4 (AZB and AZD) should be left open.

The monitor will be shipped with jumpers for the maximum number of zones available on the unit. That is a model 2004 will be jumpered for 4 zones, a 2008 for 8 zones and a 2016 for 16 zones. If you are using less than the full complement of zones, be sure to jumper for the number of zones you actually are using. If you leave the control jumpered for the full complement, time will be wasted by the control sampling the unused zones. Using our 6 zone example and assuming a model 2008, 25% of the time will be lost monitoring zones 7 and 8. Caution do not jumper for more zones than are available. For example, if your unit is a 2008 and you jumper for 10 zones, the monitor will become confused and not function appropriately.

Primary Power Wiring

Refer to Terminal Board TBP (Fig. 3). The Primary power required is either 120 volt 60 HZ or 220 volt 50 HZ depending on the unit purchased. Power is supplied to the unit through the bushing located on the left side of the box. It is strongly recommended that power be supplied from a separate disconnect, NOT by plugging into a wall socket. The System 2000 is a continuous monitor, if a wall socket is used there is a risk that the unit will inadvertently be unplugged putting it off line.

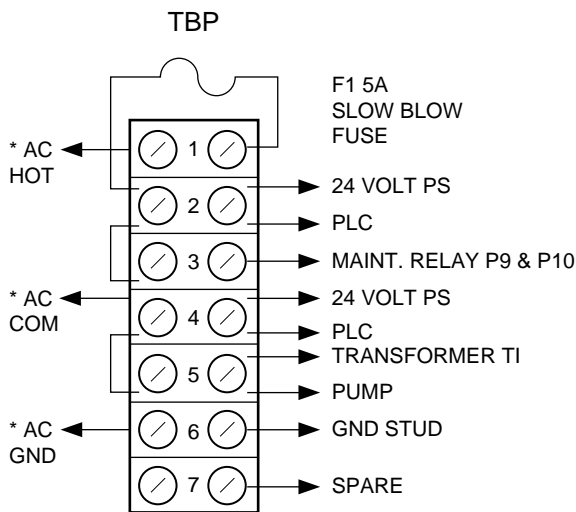

*Customer Supplied

Fig. 3
Primary Power Wiring

OPTIONAL CONNECTIONS

Refer to Fig. 4 which shows terminal board TBC.

Analog Signal: Available on Pins 1 and 2 of TBC.

Alarm Relay Contact: Used for actuating horns or strobes, as input for actuating an Automatic Dialer, as input to a customer control system, etc. (See examples shown on Fig. 4).

Double check the wiring.

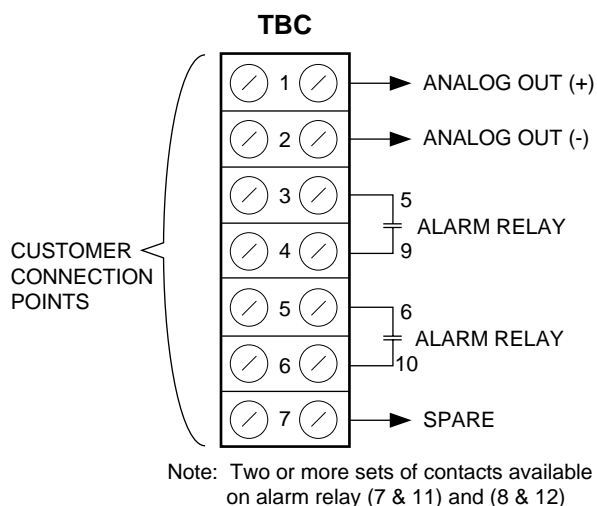

TYPICAL INTERCONNECTIONS

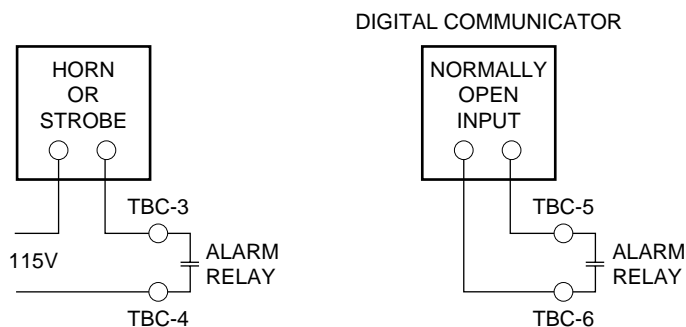

Fig. 4
Customer Connections

OPERATIONS

Before applying primary power to the System 2000, read this section in its entirety.

WARNING

THE SENSOR OPERATES AT A TEMPERATURE OF 900° CELSIUS (1650° FAHRENHEIT). IF THERE IS ANY REASON TO SUSPECT THE PRESENCE OF A COMBUSTIBLE ATMOSPHERE, THE SYSTEM SHOULD NOT BE TURNED ON UNTIL THAT HAS BEEN ELIMINATED.

Modes of Operation

The System 2000 has 2 basic operating modes, Automatic and Manual.

Automatic

When power is applied, the system starts in Automatic mode and Zone 1 (Fig. 5).

Warm-up

When power is applied or after an alarm condition has been reset, the system goes through a 3 minute warm-up period.

Normal Sequencing

After the warm-up period, the system enters normal Automatic operation, during which the system sequentially scans each selected zone. The system remains in each zone for 1 minute monitoring the air drawn from that zone. Assuming the ambient refrigerant level is less than the trip point, the system switches to the next zone. After monitoring the last selected zone, the unit switches back to zone 1 and repeats the process.

If the system detects a refrigerant level equal to or greater than the trip Point, the scanning process stops and the system remains in the suspect zone until it has determined whether or not there is in fact an excess of refrigerant present.

Leak Wait Sequence

The purpose of the wait is to avoid going into alarm for a brief transient increase in halogen background. During Leak Wait, the Leak Wait Light is lit and the analog meter oscillates between 0 and the ambient ppm reading.

Normal Leak Wait time can range from 7 seconds to 3 minutes. The more the ambient refrigerant level exceeds the trip point the shorter the wait period. When the sensor electronics has decided there is an excess of refrigerant, the Alarm Sequence is executed. If during the wait period the ambient level should drop below the trip point for more than 5 seconds, the sensor electronics will abort Leak Wait and go back to normal monitoring.

Five Minute Leak Wait

In certain unusual circumstances, the sensor electronics may remain in Leak Wait for longer than 3 minutes. If the system stays in Leak Wait for 5 minutes, an Alarm condition is assumed and the Alarm Sequence entered.

Multiple Leak Wait

If the ambient refrigerant level is right at the trip point, the unit may enter Leak Wait and then drop out again. The system keeps track of the number of times the unit enters Leak Wait mode. Should the unit enter Leak Wait mode 3 times, the system assumes an Alarm condition and the Alarm sequence is entered.

Alarm Sequence

If the system determines that there is a leak present, the alarm sequence is executed as follows.

1. Alarm Relay is energized.
2. Alarm light for that zone starts flashing.
3. The sensor electronics are reset.
4. The system switches to the next selected zone.
5. The zone that is in Alarm is taken out of the scan sequence.
6. The Warm-up sequence is repeated to clear the air system of refrigerant from the zone that went into alarm.
7. After the Warm-up is completed, the system proceeds to scan the remaining zones.

Multiple Alarms

If a second zone goes into alarm before the first problem has been cleared, the system goes through the same procedure as in the case of the first zone that went into alarm. The second zone is taken out of the sequence and the system proceeds to monitor the remaining zones.

All Zones in Alarm

In the event all zones are in alarm before the problems are cleared, the Maintenance Relay is energized shutting off the pump and the sensor electronics.

Manual

Manual mode is used for trouble shooting and for confirming that any reported leaks have indeed been repaired. In Manual Mode the system remains in the selected zone. To move from one zone to the next, it is necessary to momentarily depress the Advance Push button. The unit continues to monitor the ambient air in the selected zone. If there is an excess of refrigerant present, it will go through the Leak Wait and Alarm sequences. However, unlike Automatic Mode the unit will not reset itself and move to the next zone.

The push-buttons and indicators (Fig. 5) are described below.

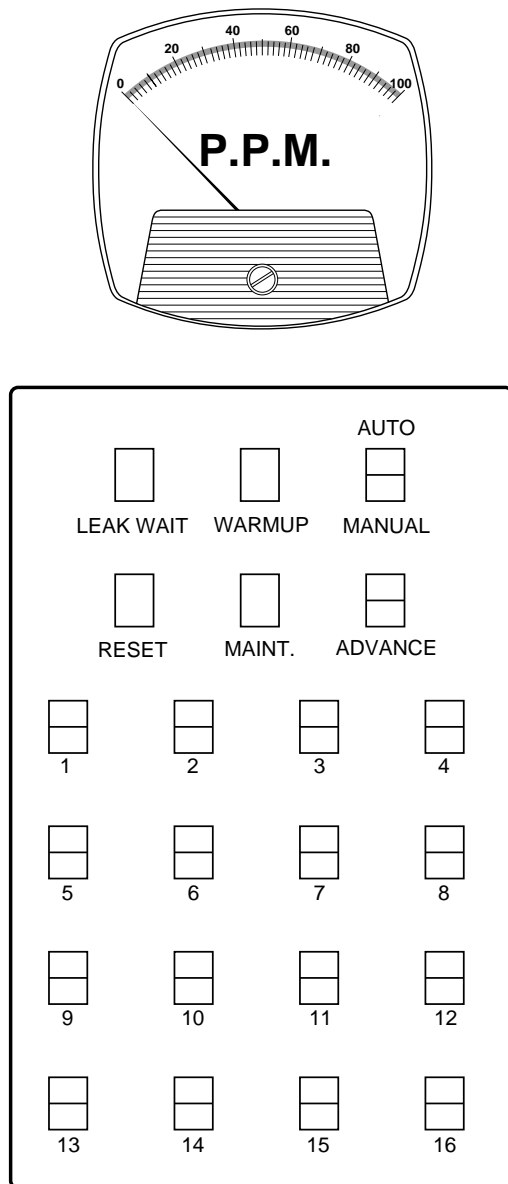

Fig. 5
Control Panel

Analog Meter

The analog meter provides a display of ambient refrigerant levels in parts per million, during monitoring mode. In Warm-up, the meter reads 0 ppm. During leak wait, the meter oscillates between 0 and the refrigerant level present. If the system goes into Alarm in Manual Mode, the meter stays at the level of refrigerant present when the system went into alarm.

Leak Wait Light

The Leak Wait Light is lit during Leak Wait Mode and at no other time.

Warm-up Light

The Warm-up Light is lit during Warm-up mode and at no other time.

Auto/Manual Lighted Push-Button

The push-button alternately selects Automatic Mode or Manual Mode. The lights indicate which mode is active.

Reset Pushbutton

The Reset push-button resets Alarm Mode and Maintenance Mode. Whenever the Reset button is actuated, the control resets the sensor electronics, and the unit enters Warm-up Mode.

Maintenance Lighted Pushbutton

This control provides a dual function. The light is an indication that a failure has occurred in the pneumatic circuit or in the sensor alarm circuitry (see the Trouble Shooting section of the manual). The push-button provides a "Push to Test" facility. When the push-button is depressed, the Alarm Relay is momentarily energized and all zone Alarm Lights are lit. This provides a means of testing any warning horns, lights, or auto dialer, and testing of the zone alarm lights.

Advance Pushbutton

Each time the Advance push-button is depressed, the system sequences to the next selected zone that is not in Alarm.

Zone Lights

The white zone light indicates which zone is active. The red zone light is illuminated when a zone goes into alarm.

START-UP



THE SENSOR OPERATES AT 90° CELSIUS (1650° FAHRENHEIT) AND 180 VOLTS. NEVER TOUCH THE SENSOR WHILE POWER IS APPLIED.

Having confirmed that the wiring is correct, apply power to the unit. Allow the unit to warm-up for 20 to 30 minutes before proceeding.

Checking Alarm and Option Wiring

Momentarily depress the Maintenance push-button to energize the Alarm Relay. This step will double check the wiring of horns, lights, and/or the automatic dialer that are set to operate when the unit goes into Alarm. It will also light all the selected Zone Alarm lights.

Checking Zone Selection

Put the system in Manual mode by depressing the Auto/Manual push-button. Using the Advance push-button step through all the selected zones. This test should confirm that all zones required have been selected and there are no unused zones in the sequence. If any of the desired zones are missing from the sequence or there are any unused zones in the sequence, go back to the zone selection section of the manual and double check the jumpers.

Checking for Proper Air Flow

These next series of tests are to confirm that the pneumatic system is functioning properly, and that all the tubing runs are continuous and unblocked.

Open the unit door so that you can monitor the flowmeter mounted on the sensor bracket. Check the factory setting for the flowmeter noted on a decal on the inside of the door.

Check for proper air flow with no tubing attached by using the Advance push-button, move to zone 1. Disconnect the tubing from that zone and compare the flow to the factory setting. The purpose of this test is to check that the flow setting did not get out of adjustment during shipping. The reading should be within 15% of the factory setting. Minor corrections can be made by adjusting the regulator (the black T shaped device after the fine filter). If any required corrections cannot be made with the regulator, turn to the Maintenance section of the manual for instructions on how to reset the flow.

Check for proper operation of the pressure switch. One of the safety features of the system is a pressure switch connected to the output of the vacuum pump. Failure of the pump or a blockage in the system will cause the pressure switch to deenergize. After a 10 second delay the Maintenance and Alarm relays will be energized and the pneumatic and sensor systems will shut down. Place your finger over the zone 1 opening to block air flow. The flowmeter reading will fall and after 15 or 20 seconds, the shut down should occur. The Maintenance light should be on and the alarms energized. If there are any problems, turn to the Maintenance section of the manual.

Check for proper flow in each zone. Reconnect the zone 1 tubing. Using the Advance push-button, step through all of the zones. The flow for each zone should not vary from the "no tube" reading by more than 20% of full scale. The shorter the tubing run the higher the flow. Observe each zone for a minute or two. If there is an obstruction at the far end of a Particularly long run, it could take that long before

the tubing is sufficiently evacuated for the flow to drop. The purpose of this test is to make certain that there are no obstructions in any of the tubing runs. If the flow in any of the zones drops excessively, disconnect the tubing from that zone. If the flow goes back to the "no tube" level, there is an obstruction somewhere in the tubing run. Before proceeding, check the tube run and clear the obstruction.

Check for no breaks in the tubing runs. The purpose of this test is to make certain that there are no discontinuities or leaks in any of the tubing runs. The test can be done most conveniently with two people one stationed at the monitor and the other at the tubing pickup points. All tubes should be connected to the monitor and the system in Manual. At the monitor end, set the system to zone 1. At the pickup point, unscrew the coarse filter from the tube. Place your finger over the end of the tube to block the air flow. If there are no breaks or leaks, you should feel a suction at the tube end. The longer the tube run, the more "gentle" the suction. Proceed to check all the pick up points in this manner. This

test will confirm that there are no discontinuities, and that each zone tube is indeed connected to the correct zone inlet of the monitor.

Checking the Sensor System

Reconnect any zone tube that may have been disconnected as part of your testing to this point. The following test will confirm that the sensor system is operating properly. By now the system should have been operating for several hours and should be thoroughly warmed up. If that is not the case, allow the system to warm-up for at least 30 minutes before proceeding (2 or 3 hours is preferable since the system has been off for a number of days or weeks since shipped from the factory).

Step 1: Push the Auto/Manual push-button to set the system to Manual mode. Using the Advance push-button, slowly step through each zone, and make a note of the ppm meter readings. The readings should be less than 5 ppm in each zone. If the reading is 10 ppm or higher in any zone or the system has gone into the Leak Wait Mode or Alarm Mode, there is a likelihood that there is a leak present in that zone. A high reading may also result from the recent use of a chlorinated cleaning agent. Many industrial degreasers do use chlorine based compounds. Some examples are trichloroethylene and perchloroethylene based solvents or cleaners. If you are convinced that there is no leak, and that there are no other sources of halogen vapors in the room, turn to the Maintenance section of the manual.

Step 2: Using the Advance push-button, select a zone to use for the set up procedures. Remove the inlet tubing from the selected zone so that you can introduce refrigerant into that zone for testing.

Step 3: The trip point setting of the unit is written on the inside front cover of the unit. Make a note of the setting.

Step 4: To check for proper operation of the Monitoring, Leak Wait, and Alarm modes, it is necessary to prepare a sample of the refrigerant gas being used.

CAUTION

VERY HIGH CONCENTRATIONS OF REFRIGERANT CAN SIGNIFICANTLY SHORTEN SENSOR LIFE. NEVER SQUIRT PURE REFRIGERANT TOWARDS THE SENSOR OPENING.

a) Gaseous Refrigerants: Obtain a small Plastic garbage bag (waste basket size is fine). Open the bag and "fluff" it so that it is full of air. Insert a refrigerant fill hose into the bag opening. Close the mouth of the bag around the hose. Crack the valve for a second or less so that a small "squirt" of refrigerant enters the bag. Keep in mind the monitor reads in parts per million and a tiny amount of gas will make a relatively high concentration sample. Pull out the hose, and hold the bag tightly closed.

b) Liquid Refrigerants: Obtain a small plastic "Ziplock" food storage bag. open the bag slightly and put in a few drops of liquid refrigerant. Flatten the bag so that there is little air and seal it as tightly as you can. Warm the bag to gasify the refrigerant. The bag will expand as the liquid evaporates, but the seal should be good enough to keep any from escaping.

Step 5: Test to see that Leak Wait and Alarm Mode work. We are going to use our refrigerant sample to simulate a concentration of refrigerant in the air that is reasonably higher than the trip point. **NOTE: THE MORE THE READING EXCEEDS THE TRIP POINT THE SHORTER THE LEAK WAIT TIME.**

a) Gaseous refrigerants: Holding the bag tightly closed, bring the bag to just under the inlet of the zone you have selected. Carefully loosen your grip on the bag to allow some contents to come out. Watch the meter as you do this. You should try and allow enough gas to leak to cause the meter to rise to 60 to 90 ppm. Precision is not possible, and the goal is to see the unit enters Leak Wait mode and then Alarm mode.

b) Liquid refrigerants: Using a pin or paper clip, prick a hole in the bag. Hold the bag just under the inlet of the zone you have selected. Squeeze the bag slightly and watch the meter. You should try and allow enough gas to leak to cause the meter to rise to 60 to 90 ppm. Precision is not possible, and the goal is to see the unit enter Leak Wait mode and then Alarm mode.

Step 6: The system should now be in Alarm Mode. Confirm that the Zone Alarm light is flashing and the analog meter is steadily reading a ppm level. Check that any optional horns lights, or other devices are appropriately energized.

Step 7: Push the Manual Reset push-button to clear the alarm. Push the Advance push-button to move to another zone so that the refrigerant can be cleared from the unit during the warm-up period. Reconnect the tubing.

Step 8: Dispose of the gas samples in an appropriate manner.

Step 9: Push Auto/Manual push-button to put the unit into Automatic mode.

Step 10: Fill out the CTS/Warranty card completely and return to SenTech.

IMPORTANT

TO VALIDATE YOUR WARRANTY, THE CTS FORM MUST BE COMPLETED AND RETURNED TO THE FACTORY WITHIN THIRTY (30) DAYS OF INSTALLATION.

Step 11: Store this manual in safe place so that it will be available for future reference.

Basic installation and start-up are now complete, and the unit should be in Automatic Mode sequencing through the zones and on line and monitoring.

FINE TUNING

The trip point is set at the factory for typical background conditions. However this setting may not be optimum for your specific circumstances. The threshold may be higher than it needs to be and it will take longer to catch small leaks. Conversely, even after eliminating any preexisting leaks, your background may be higher than typical for a variety of reasons. Under those conditions the likelihood of random false alarms may be increased with the factory set trip point. Therefore, it may be desirable to fine tune the System 2000 trip point. If that is the case follow the steps outlined below.

Step 1: For the next two weeks, check and note the ppm reading daily or even better 2 or 3 times per day for each selected zone. Vary the time(s) of day that you make the checks so you can arrive at a reasonably accurate estimate of your typical peak background condition. (If the reading steadily increases in any zone, you may have a developing leak and it should be repaired before proceeding.)

Step 2: Reset the trip point.

⚠ CAUTION

IF ONE OR MORE OF THE ZONES BEING MONITORED HAS REFRIGERANT 123 PRESENT, THE TRIP POINT SHOULD NOT BE SET HIGHER THAN 30 PPM, THE CURRENTLY RECOMMENDED AEL (ACCEPTABLE ENVIRONMENTAL LEVEL).

Case A

Maximize early leak detection/tolerant of occasional false alarms.

Background PPM	Trip Point PPM
less than 2	10 or less
3 - 5	15
6 - 10	25
11 - 15	35

Case B

Keep false alarms to a minimum.

Background PPM	Trip Point PPM
less than 2	15
3 - 5	25
6 - 10	35
11 - 15	45

When you have decided on an appropriate trip Point setting for your application, refer to Appendix A for instructions on how to set the trip Point. Once you have reset the trip point, make a note of the new trip setting, the date, and your signature on the trip point setting label. This information is essential for troubleshooting any future problems.

PERIODIC PERFORMANCE CHECKS

Weekly

Check that the system is sequencing through all selected zones. While it sequences, monitor the flowmeter to check that there are no obstructions in the tubing.

Momentarily depress the Maintenance push-button. Make certain that all Zone Alarm lights work, that any horns and strobes are actuated.

Quarterly

Go through steps 2 through 9 of the start up instructions, to check proper functioning of the Leak Wait and Alarm modes.

PREVENTIVE MAINTENANCE CHECKS

The only preventive maintenance that needs to be accomplished on a routine basis is to periodically clean the filters.

Cooling Air Filters

There are two air filters on the outside of the box, one for inlet cooling air and the other for outlet cooling air. Dirty filters will reduce cooling air flow and could shorten the life of the solid state electronics.

Tube End Coarse Filters

Dirt and grease on the tube end filters will restrict air flow and increase the time for a sample to reach the monitor.

Optional In-line Filter Separators

These filters should be installed in any zones that are particularly dirty and/or where there is a risk of moisture entering the system.

Pump Filters

There are two filters on the inlet and outlet of the pump inside the System 2000 box. Dirt and moisture droplets will degrade the sensor and shorten its life.

Sensor Fine Filter

In the sensor leg of the pneumatic system there is a final fine (5 micron) filter to protect the regulator, orifice, flowmeter, and sensor.

How often to clean the filters depends on how dirty the air is in the vicinity of the monitor and at the pickup points. The following recommendations are a starting point.

Filter Cleaning Recommendations:

1. For the first three months of operation, check all the filters at least monthly to determine how quickly each filter gets dirty, and establish a maintenance schedule based on that data.

2. The pump outlet filter will collect some carbon dust during the first few months of operation. This is a result of the pump's graphite vanes seating themselves and should not be a concern unless the filter bottle starts to collect substantial quantities of dust and/or the flowmeter readings start to go down.
3. Because of the other filters in series, the pump outlet filter and the sensor fine filter should rarely require cleaning, but they should be checked when the other filters are cleaned.
4. At the very minimum, the cooling air filters should be cleaned and the other filters checked and cleaned, if necessary, at least quarterly.

MAINTENANCE & TROUBLE SHOOTING

(See also page 23 **Trouble Shooting Guide**)

Maintenance

The System 2000 can be partitioned into three major subsystems. These are the pneumatics or air sampling system; the sensor and sensor electronics; and the PLC or programmable logic controller. Note that the following discussion is based on a System 2016, or 16 zone system. All of the discussion is relevant to a 2004 or 2008 system. The only difference in the pneumatic subsystem is that a 2004 has only one bank of inlet manifold/valve assemblies and the 2008 has 2 banks of inlet/manifold assemblies.

Pneumatic Subsystem (refer to Fig. 6)

The heart of the Pneumatic System is the vacuum pump which sequentially draws the air sample from each of the zones being monitored. The air is compressed to a pressure of 4 psig (pounds/square inch gauge). A small portion of the sample air is diverted to the sensor and the remainder is exhausted. The vacuum pump has been sized so that for the longest recommended tube run, 500 feet (120 meters), it will take 20 to 25 seconds for a new sample to reach the sensor.

Starting at the location to be sensed, the tubing is terminated with a coarse filter assembly. If the area to be sensed is particularly dirty and/or there is any risk of water entering the system, the optional filter/separator assembly should be in series with the tubing. This unit should be mounted at a convenient location near the pickup point. At the System 2000, the tubing is connected to the inlet port selected for that zone. Recall from the Zone Selection section of the manual, the tubing has to be installed starting with zone 1 (upper left hand inlet port) and continued in sequence.

In series with each inlet port, there is a solenoid valve that is controlled by the PLC. The valves are energized, one at a time, sequentially, starting with zone 1 and continuing until the last selected zone is energized, at which point the system returns to zone 1 and repeats the process. The manifolds are interconnected and the assembly is connected to the inlet filter of the pump.

The outlet filter is connected to a cross fitting. One arm of the cross is connected through a tee to the pressure gauge and then the pressure relief exhaust valve. Another arm is connected to the pressure switch which must be actuated for the system to operate. The third arm is connected to the subsystem which delivers the sample air to the sensor.

The air to the sensor first passes through a 5 micron filter, a pressure regulator, an orifice, a flowmeter and then the sensor. A decal on the inside of the front door of the unit shows the flow setting that was used in calibration and setup of the unit. The sensor electronics compensate for variations in flow through the sensor.

The flow rate is a function of the pressure at the inlet of the orifice and the orifice size. The pressure at the inlet of the orifice is set by the pressure regulator. The regulator can control pressure from 0.1 to 10 psi. For the regulator to control its outlet pressure, the inlet pressure must be several psi higher than the desired outlet setting. The inlet pressure of the regulator is set by the adjustable pressure

relief valve at the exhaust.

Resetting Sensor Air Flow

Put the system in Manual mode and select a zone that will be convenient for disconnecting the tubing. Sensor flow adjustments should be done with no tubing connected. Disconnect the tubing from that zone. Make a note of the flow setting used when the unit was calibrated at the factory.

Correcting for relatively small variations in sensor air flow can be accomplished by adjusting the regulator.

A major readjustment that may become necessary because of a component change requires a two step process.

1. Loosen the locking nut on the pressure relief valve. Adjust the valve until the pressure gauge reads in the range of 4 psi. Retighten the lock nut making it as secure as you can.
2. Adjust the pressure regulator to achieve the required air flow.

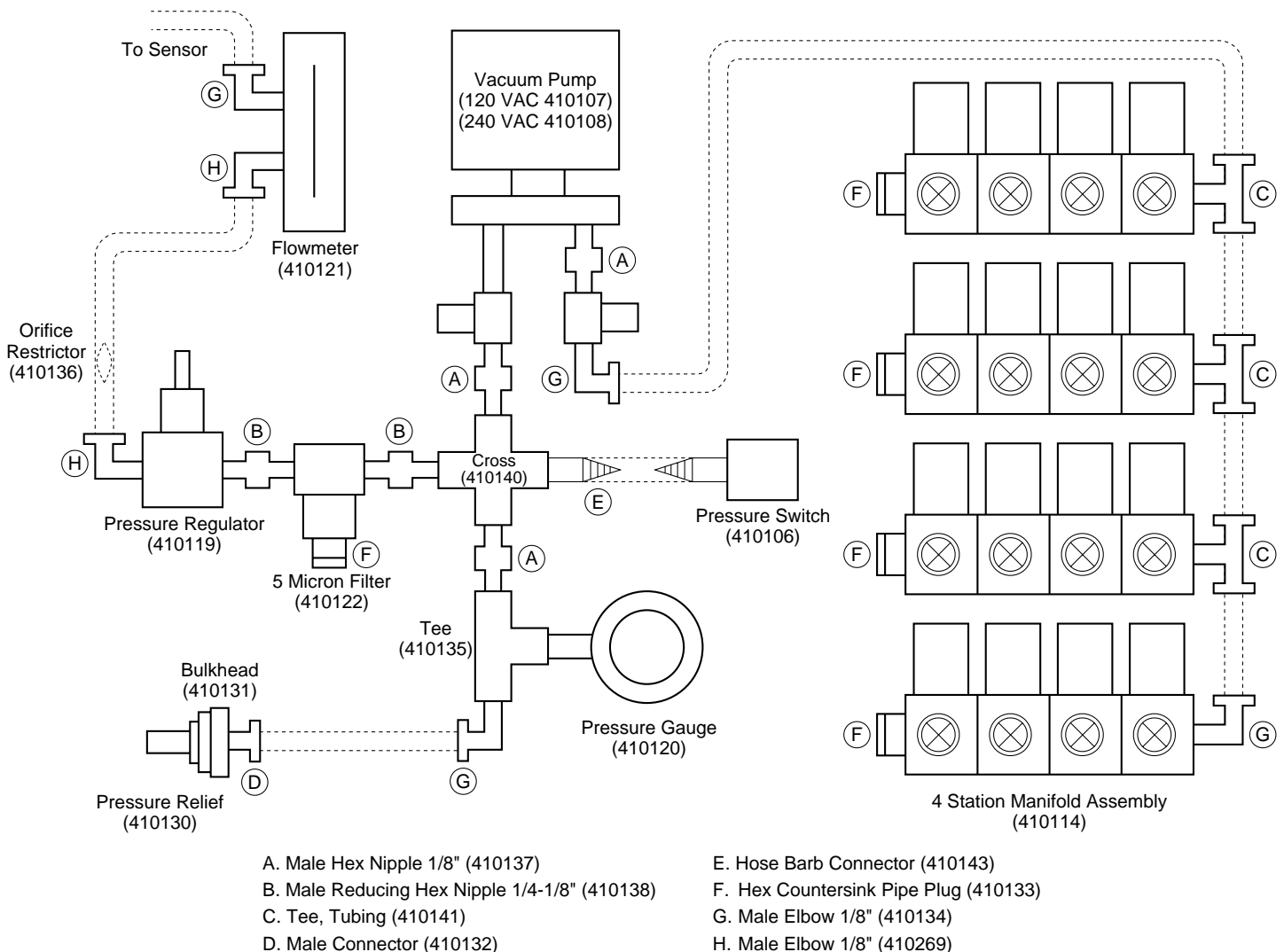

Fig. 6
Pneumatic Subsystem Schematic

Reconnect the tubing. Manually sequence through all the selected zones to double check that there are no problems in any of the tube runs.

Pressure Switch

The purpose of the pressure switch is to shut down the system if there is a pump failure or a major blockage in one of the tube runs. It is a 0.5-10 psi switch that is normally set to actuate at approximately .5-1 psi. The normally closed contacts are used so that when there is insufficient pressure there is a 24 volt signal to the PLC. The signal is called FS1 and is input to the PLC main unit at position X6. (See the PLC section of this manual for a discussion of the PLC). There is a 10 second delay in the PLC logic so that when the unit is first turned on, there is time for the pressure to build and actuate the switch before a shut down is executed. If there is a failure and the switch deactuates, the Maintenance relay is energized after the 10 second delay. When the relay is energized, power is removed from the pump and the sensor electronics.

Resetting the Pressure Switch

The pressure switch is set at the factory, and is unlikely to need readjustment unless there is a failure and it has to be replaced.

1. Turn the pressure switch adjustment screw until approximately one (1) thread is showing.
2. Disconnect the tubing from one of the zones.
3. Switch to Manual mode and advance to the zone from which you disconnected the tubing.
4. Place your finger over the zone input to block air flow. The flowmeter reading will drop, and after 15-29 seconds shut down should occur.
5. Reconnect the tubing.

Checking for Pneumatic System Failures

The first step in checking for a pneumatic system failure is to eliminate the other reasons for energizing the Maintenance relay.

The Maintenance relay will also be energized when all zones are in Alarm. If this is the case, all the selected zone Alarm lights will be flashing. Push Reset.

The system should come back on in Warm-up mode, with the pneumatic system operating normally. Proceed to solve the leak problem(s).

The second cause for actuating the Maintenance relay is a failure in the control board alarm circuitry. In this situation, at least one zone but not all should be in Alarm and the X4 LED on the PLC may be lit. If this is the case, turn to the sensor electronics portion of this section.

Assuming the other two reasons for energizing the Maintenance relay have been eliminated, the source of the problem is the pneumatic system.

Programmable Logic Control (PLC)

The System 2000 is under the continuous control of the Programmable Logic Controller (PLC). As soon as power is supplied to the system (or after a power interruption), the PLC starts running. It comes on in Automatic mode, at zone 1, and in Warm-up. When Warm-up is completed, it proceeds to sequence through the selected zones monitoring for leaks. As with the pneumatic system, the following discussion will be based on a model 2016, 16 zone unit. The only difference between the models are that a 2004 has a single PLC base unit, the 2008 has an additional output block, and the 2016 has two output blocks. For the following discussion, refer to the system schematic and wiring diagram.

Inputs to the PLC include: the front panel push-buttons, 2 inputs from the sensor electronics, and the pressure switch signal. Outputs from the PLC control the lights, the zone valves, and 3 Relays. All the inputs and outputs are 24 Volts DC. Power to the PLC can be 100 to 240 Volts AC, 50 to 60 Hz. An input logical "1" or "ON" is 24 Volts, a logic "0" is 0 Volts. Similarly an output logic "1" is 24 volts.

Input/Output Names and Locations

The PLC Input/Output Chart shows all the PLC inputs and outputs, their logic designations and descriptions. The logic X's are inputs and the Y's are outputs. The first column of the chart is the logic designation that is used by the internal program. The second column shows the connection point to the PLC. PLC1T-X0 means the X0 connection on the upper set of terminal strips of PLC unit 1 (the left most unit). PLC2B-Y3 means the Y3 connection on the lower set of terminal strips of unit 2 (the middle unit). The third column "Mnemonic" is the abbreviated name of the logic signal. The fourth column is a description of the signal. The final column shows the connection point(s) in the System 2000.

Logic Description

All of the inputs except the Leak Wait signal are positive logic. That is a logic 1 or +24 Volts means something should happen or the signal is present or ON. The Leak Wait signal is the only reverse logic input. When the +24 is present, it is NOT Leak Wait, 0 Volts indicates that the system is in Leak Wait mode. All of the push-buttons are momentary signals, any necessary latching is done internally by the PLC logic. To eliminate contact bounce and "relay race" problems, the Auto/Manual and Manual Reset push-buttons complete their actions only after they are released. The Push to Test signal (Maintenance push-button) takes effect immediately. The Advance push-button steps the sequence one zone when it is actuated, but it must be released and depressed again to move to the following zone. All of the outputs are positive logic, +24 Volts means the output is on.

Inputs

Push-buttons

The functions of the push-buttons are described in some detail in the Operations section of the manual.

Leak Wait X2

When the Leak Wait signal is 0 volts, the sensor electronics is in the Leak Wait mode.

Alarm X4

When the signal is 24 volts, the sensor electronics is in Alarm mode. Note that during System 2000 Automatic operation, Alarm mode is immediately reset by the PLC and the system is switched to the next zone. In Manual mode, the signal is present until there is a Manual Reset.

Pressure Switch X6

When the X6 is high, it indicates that the pressure is below the pressure switch setting and there may be a problem with the pneumatic system.

Allow Zone X7-X12

These signals are used to select the number of zones to be scanned. Refer to the Zone Selection section of the manual for a description of their function.

Outputs

Control Panel Lights

The functions of the lights are described in some detail in the Operations section of the manual.

Reset Relay Y2

The Reset Relay is energized by the PLC when a reset is required. A contact of the relay is used to reset the sensor electronics.

Alarm Relay Y3

The Alarm Relay is energized by the PLC when an alarm condition occurs. It is maintained until there is a Manual Reset. The Alarm Relay contacts are available to the user for external signaling devices.

Maintenance Relay Y5

The Maintenance Relay is energized by the PLC whenever any of the Maintenance Mode conditions occur. Its contacts are used to deenergize the vacuum pump and the sensor electronics.

Zone On Y10-Y13, Y20-Y23, Y30-Y33, Y40-Y43

These outputs energize the zone solenoid valves.

Miscellaneous PLC Connections

In addition to the inputs and outputs, there are several other connections to the PLC. These include: line voltage to power the unit, a jumper from the internal 24V to the run input, a jumper between SS and OV to define a +24 input as a logic 1, a connection between the PLC OV and the system 2000 common, jumpers to connect all the SG terminals, and the +24 volts to power the outputs.

Checking for PLC Failures

Each PLC unit has two sets of red light emitting diodes, LED's associated with each bank of inputs and outputs. When the LED is lit, it means the input or output is in the logic 1 or ON condition. The LED's provide a useful tool for troubleshooting. For example, if depressing a push-button, the desired affect does not occur, by checking the LED you can determine whether the signal is reaching the PLC. Additionally, the PLC base unit has two green LED's that show power on, and whether the system is running the program. There are also two red LED's, one for low battery voltage and one that shows a program error.

The program in the PLC is in EPROM memory so there is no need to be concerned about internal battery life. When power is applied to the system, the PLC loads the EPROM program into active memory. If the error LED is lit or there is a concern that there may be a problem with the program, deenergizing the system and then reapplying power will reload the program.

If the green RUN LED is not lit, check for the jumper between the PLC 24V and RUN.

Sensor Electronics

The sensor operates by heating the sampled air to a temperature of approximately 900° Celsius. This ionizes any halogen based hydrocarbons present in the sample. The ions are attracted to the collector of the sensor, resulting in a small current flow. The amount of current is proportional to the relative concentration of the refrigerant in the air.

The sensor electronics are divided into two major sections. One section provides the necessary current and voltages to the sensor and detects the output signal current. The second section contains the microprocessor digital control elements that analyze the sensor signal, compare it to the trip point, and provides the necessary outputs to the PLC.

Sensor Power Circuit (Fig. 7)

Figure 7 is a block diagram of the sensor power circuit. Power for the sensor drive enters the main board on pins J1-1 and J1-2. After fuse F1, bridge BR2 provides DC power to the sensor filament circuit. Note that the filament current portion of the circuit is tied to the high voltage so that the entire filament supply portion of the electronics is referenced to the 180 volts DC and not to ground or common.

Filament current is provided to the sensor through power transistor Q2 which is controlled by the pulse width modulator (PWM). The pulses from Q2 are smoothed by the filter section, and then output to the sensor on pins J2-2 and J2-3.

During operation, the filament current is controlled by the bridge circuit. The sensitivity and calibration of the unit depend strongly on the temperature of the heated air sample. The filament is a platinum wire which is an

PLC INPUT/OUTPUT

PLC LOGIC DESIGNATION	PLC LOCATION	MNEMONIC	SIGNAL DESCRIPTION	2000 CONNECTION
X0	PLC1T-X0	AM	AUTO/MANUAL SELECTION	AUTO/MANUAL PB
X1	PLC1T-X1	MBLW	LEAK WAIT SIGNAL FROM CONTROL BOARD	TBJ-1, LEAK WAIT LIGHT
X2	PLC1T-X2	MRES	MANUAL RESET	MANUAL RESET PB
X3	PLC1T-X3	ADV	ADVANCE	ADVANCE PB
X4	PLC1T-X4	MBALRM	ALARM SIGNAL FROM CONTROL BOARD	CONTROL BOARD J2-7
X5	PLC1T-X5	PTT	PUSH TO TEST	MAINTENANCE PB
X6	PLC1T-X6	FSI	PRESSURE SWITCH SIGNAL	PRESSURE SWITCH N/C CONTACT
X7	PLC1T-X7	AZA	ALLOW ZONE A	TBDC-1
X10	PLC1T-X10	AZB	ALLOW ZONE B	TBDC-2
X11	PLC1T-X11	AZC	ALLOW ZONE C	TBDC-3
X12	PLC1T-X12	AZD	ALLOW ZONE D	TBDC-4
Y0	PLC1B-Y0	AUTO	AUTOMATIC MODE	AUTO LIGHT
Y1	PLC1B-Y1	MAN	MANUAL MODE	MANUAL LIGHT
Y2	PLC1B-Y2	RESR	RESET RELAY	RESET RELAY COIL PIN 13
Y3	PLC1B-Y3	ALRMR	ALARM RELAY	ALARM RELAY COIL PIN 13
Y4	PLC1B-Y4	WUP	WARM UP MODE	WARM UP LIGHT
Y5	PLC1B-Y5	MNR	MAINTENANCE RELAY	MAINTENANCE RELAY COIL PIN 13
Y6	PLC1B-Y6	MNL	MAINTENANCE MODE	MAINTENANCE LIGHT
Y7	NOT USED	NOT USED	NOT USED	NOT USED
Y10	PLC1B-Y10	Z1 ON	ZONE 1 ON	TBB1-4 ZONE 1 VALVE AND LIGHT
Y11	PLC1B-Y11	Z2 ON	ZONE 2 ON	TBB1-5 ZONE 2 VALVE AND LIGHT
Y12	PLC1B-Y12	Z3 ON	ZONE 3 ON	TBB1-6 ZONE 3 VALVE AND LIGHT
Y13	PLC1B-Y13	Z4 ON	ZONE 4 ON	TBB1-7 ZONE 4 VALVE AND LIGHT
Y14	PLC1B-Y14	Z1 ALRM	ZONE 1 ALARM	ZONE 1 ALARM LIGHT
Y15	PLC1B-Y15	Z2 ALRM	ZONE 2 ALARM	ZONE 2 ALARM LIGHT
Y16	PLC1B-Y16	Z3 ALRM	ZONE 3 ALARM	ZONE 3 ALARM LIGHT
Y17	PLC1B-Y17	Z4 ALRM	ZONE 4 ALARM	ZONE 4 ALARM LIGHT
Y20	PLC2T-Y0	Z5 ON	ZONE 5 ON (USED ON 2008 & 2016)	TBB2-4 ZONE 5 VALVE AND LIGHT
Y21	PLC2T-Y1	Z6 ON	ZONE 6 ON (USED ON 2008 & 2016)	TBB2-5 ZONE 6 VALVE AND LIGHT
Y22	PLC2T-Y2	Z7 ON	ZONE 7 ON (USED ON 2008 & 2016)	TBB2-6 ZONE 7 VALVE AND LIGHT
Y23	PLC2T-Y3	Z8 ON	ZONE 8 ON (USED ON 2008 & 2016)	TBB2-7 ZONE 8 VALVE AND LIGHT
Y24	PLC2T-Y4	Z5ALRM	ZONE 5 ALARM (USED ON 2008 & 2016)	ZONE 5 ALARM LIGHT
Y25	PLC2T-Y5	Z6ALRM	ZONE 6 ALARM (USED ON 2008 & 2016)	ZONE 6 ALARM LIGHT
Y26	PLC2T-Y6	Z7ALRM	ZONE 7 ALARM (USED ON 2008 & 2016)	ZONE 7 ALARM LIGHT
Y27	PLC2T-Y7	Z8ALRM	ZONE 8 ALARM (USED ON 2008 & 2016)	ZONE 8 ALARM LIGHT
Y30	PLC2B-Y0	Z9 ON	ZONE 9 ON (USED ON 2016 ONLY)	TBB3-4 ZONE 9 VALVE AND LIGHT
Y31	PLC2B-Y1	Z10 ON	ZONE 10 ON (USED ON 2016 ONLY)	TBB3-5 ZONE 10 VALVE AND LIGHT
Y32	PLC2B-Y2	Z11 ON	ZONE 11 ON (USED ON 2016 ONLY)	TBB3-6 ZONE 11 VALVE AND LIGHT
Y33	PLC2B-Y3	Z12 ON	ZONE 12 ON (USED ON 2016 ONLY)	TBB3-7 ZONE 12 VALVE AND LIGHT
Y34	PLC2B-Y4	Z9ALRM	ZONE 9 ALARM (USED ON 2016 ONLY)	ZONE 9 ALARM LIGHT
Y35	PLC2B-Y5	Z10ALRM	ZONE 10 ALARM (USED ON 2016 ONLY)	ZONE 10 ALARM LIGHT
Y36	PLC2B-Y6	Z11ALRM	ZONE 11 ALARM (USED ON 2016 ONLY)	ZONE 11 ALARM LIGHT
Y37	PLC2B-Y7	Z12ALRM	ZONE 12 ALARM (USED ON 2016 ONLY)	ZONE 12 ALARM LIGHT
Y40	PLC3T-Y0	Z13 ON	ZONE 13 ON (USED ON 2016 ONLY)	TBB4-4 ZONE 13 VALVE AND LIGHT
Y41	PLC3T-Y1	Z14 ON	ZONE 14 ON (USED ON 2016 ONLY)	TBB4-5 ZONE 14 VALVE AND LIGHT
Y42	PLC3T-Y2	Z15 ON	ZONE 15 ON (USED ON 2016 ONLY)	TBB4-6 ZONE 15 VALVE AND LIGHT
Y43	PLC3T-Y3	Z16 ON	ZONE 16 ON (USED ON 2016 ONLY)	TBB4-7 ZONE 16 VALVE AND LIGHT
Y44	PLC3T-Y4	Z13ALRM	ZONE 13 ALARM (USED ON 2016 ONLY)	ZONE 13 ALARM LIGHT
Y45	PLC3T-Y5	Z14ALRM	ZONE 14 ALARM (USED ON 2016 ONLY)	ZONE 14 ALARM LIGHT
Y46	PLC3T-Y6	Z15ALRM	ZONE 15 ALARM (USED ON 2016 ONLY)	ZONE 15 ALARM LIGHT
Y47	PLC3T-Y7	Z16ALRM	ZONE 16 ALARM (USED ON 2016 ONLY)	ZONE 16 ALARM LIGHT

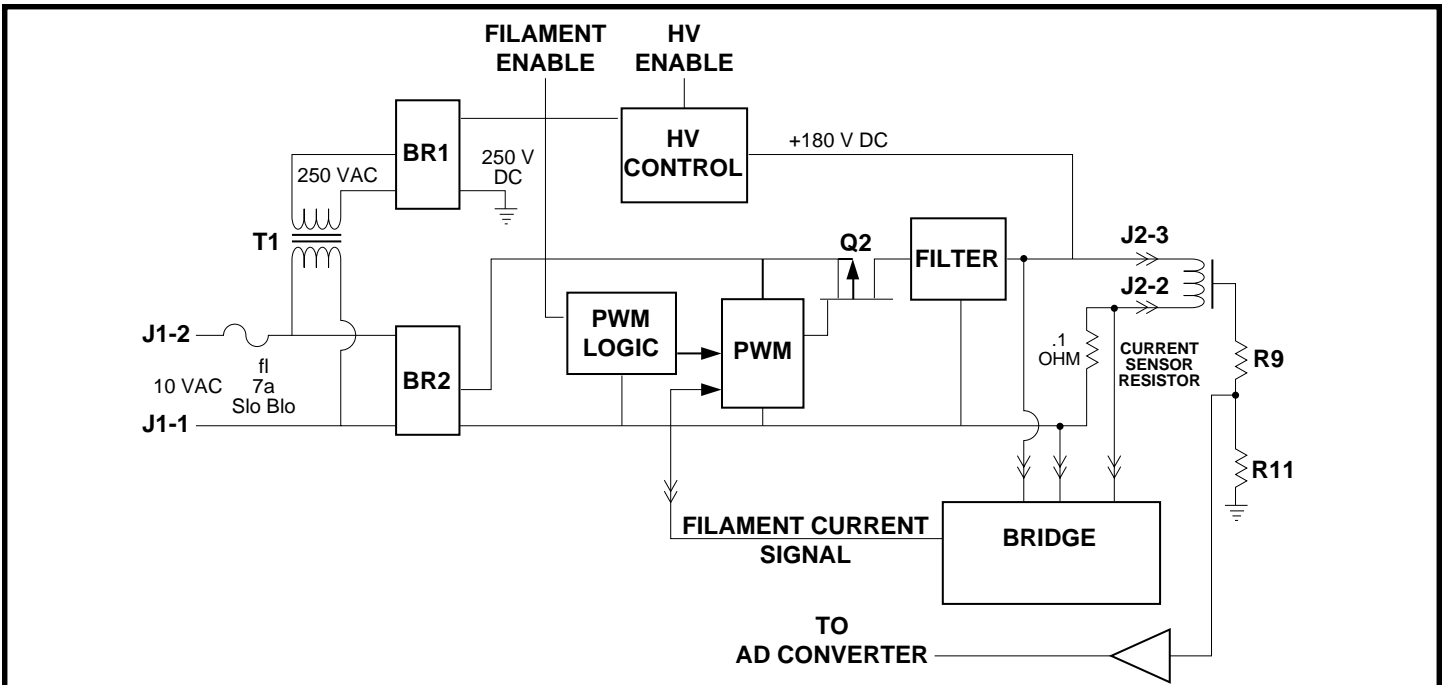

Fig. 7
Sensor Power Circuit

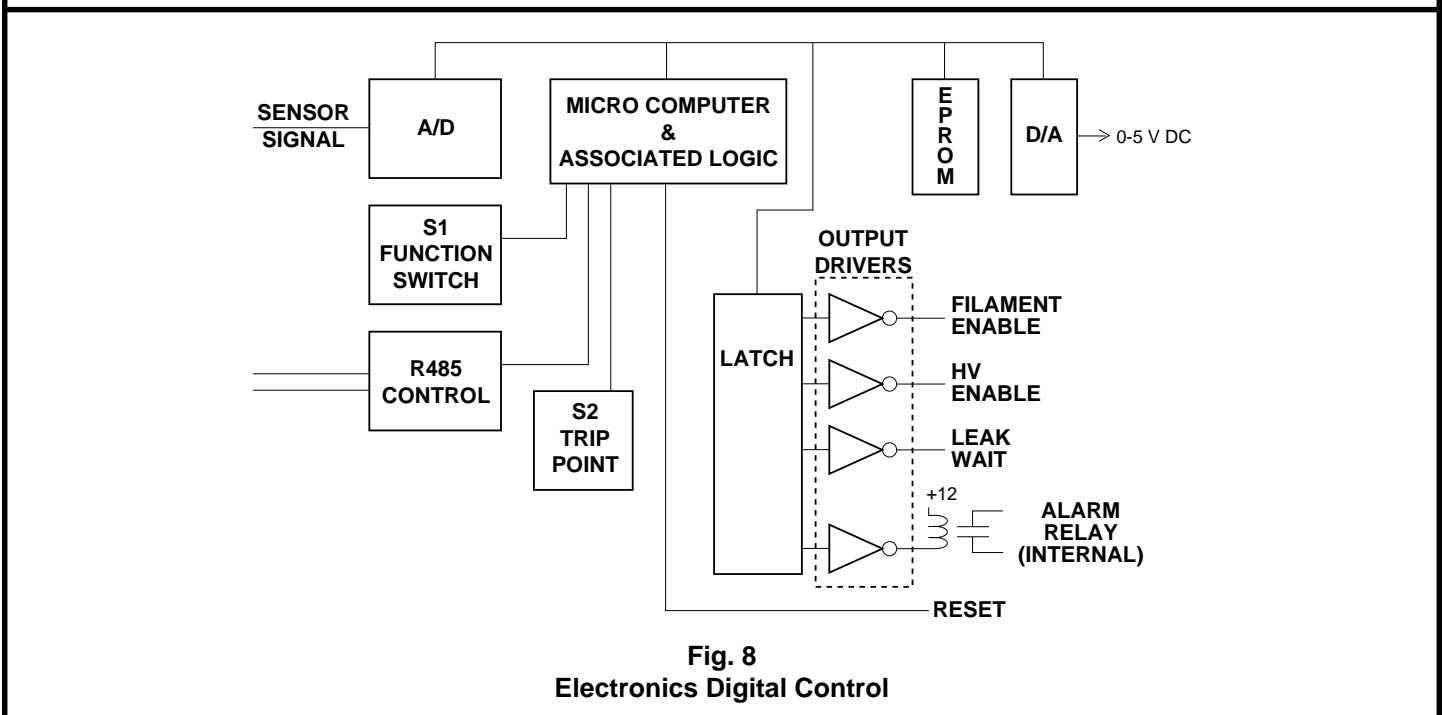

Fig. 8
Electronics Digital Control

excellent temperature sensor. Therefore, to compensate for changes in ambient air temperature and any fluctuations in air flow through the sensor, it is necessary to accurately control the temperature of the filament.

Control of the filament temperature is accomplished by the bridge. The filament and the 0.1 OHM resistor are two legs of a Wheatstone bridge. The other two legs are a combination of precision resistors and a current (hence temperature) setting potentiometer. The error signal from the Wheatstone bridge is summed with a base current setting, and the combined signal is the input to the PWM.

Any external changes such as ambient air temperature will be detected by the bridge and will change the signal to the PWM, which will then adjust the filament current to compensate for the change.

The filament enable signal comes from the digital electronics and it either allows or blocks the filament current depending on the status of the system. Similarly the high voltage enable (HV) signal either blocks or allows high voltage to be applied to the sensor depending on system status. Additionally the PWM logic provides a current limiting signal to the PWM. When the sensor is cool the filament resistance is quite low, so current is

limited to a maximum of 5 amps.

Once the sensor is warmed up, its normal operating current ranges from 3.5 to 4 amps dc.

When the sensor is at operating temperature and high voltage is enabled, the signal current flows through the voltage divider network composed of R9 and R11. The voltage across R11 is buffered by a unity gain amplifier and then supplied to the analog to digital convertor of the digital control portion of the main board.

The sensor signal can range from 0.1 volts or less when there are no refrigerants present to a high of 1.5 volts at 100 ppm when the system is calibrated for 100 ppm full scale.

Digital Control (Fig. 8)

Figure 8 is a block diagram of the microprocessor based control circuit. This circuitry provides two main functions. First, it analyzes the sensor signal and takes any action required. Second, it controls the process and does the necessary interfacing with the rest of the system.

The first step in analyzing the sensor signal is to convert the analog voltage to a digital word. Because the sensor output is not linearly related to the refrigerant concentration, the next step is to compare the digital value to a calibration table, and develop a digital word that is directly proportional to the ppm level. The "refined" sensor level is then input to a digital to analog converter which supplies a 0 to 5 volt output signal that goes to the ppm meter and is available to the user.

The calibrated sensor level is also compared to the trip point setting on switch S2. If the sensor level equals or exceeds the trip point, the system goes through the leak wait timing procedure. If the sensor level remains equal or above the trip point, the system goes into Alarm Mode.

The EPROM contains the program for running the system. The RS485 circuitry provides a means for the system to talk to an external computer via a serial communications port. The latch and output drivers provide an interface to the sensor power circuit.

The system has several operating modes. When power is first applied or after a reset, the system is in Warm-up Mode. The filament is enabled. High voltage is off. The D/A output is set at 0 volts and the Alarm relay is deenergized. After 2.5 minutes, high voltage is enabled and the D/A displays the calibrated sensor signal, but there is no testing for a leak condition. After an additional 30 seconds, the system goes into normal monitoring mode waiting for a potential leak.

When the sensor signal equals or exceeds the trip point, the system enters Leak Wait mode. In Leak Wait, the D/A output is alternately turned on and off causing the meter

reading to oscillate between 0 and the actual ppm level and the Leak Wait signal is turned on. The system waits for 5 seconds to confirm that there is a leak condition. Should the PPM level fall below the trip point during this period, the system reverts to monitoring mode.

If the ppm level remains at or above the trip point, the system starts another leak wait timing period. This second time period is variable depending on the size of the difference between the trip point and the actual ppm level. For maximum signals, the delay is two (2) seconds, and for minimum signals the delay can be up to three (3) minutes. This timing is to eliminate false alarms caused by transient conditions.

If during this second time period, the ppm signal falls below the trip point, the second timer is stopped and the original five (5) second timer is reinitiated. If the signal stays below the trip point, leak wait is aborted and the system goes back to monitoring. If the ppm level rises to the trip point or above before the five (5) seconds are up, the second time period is resumed. After the second timer times out, the system goes into Alarm Mode.

In Alarm Mode, the Alarm Relay is energized. High voltage and filament current are shut off.

The D/A output is left at the the last ppm level that existed as the system went into Alarm mode. The system now waits for an external reset. If the System 2000 is in Automatic mode, the PLC switches to the next zone and resets the sensor electronics to Warm-up.

Function switch S1 provides a means of putting the system in Test Mode. Please note that Test Mode should only be used for trouble shooting. For normal operation, the function switch **MUST** be in Run Mode.

In Test Mode, high voltage and filament current are enabled. The system ignores the trip point setting and will not go into Leak Wait or Alarm. It simply continues to monitor the ppm level and provide an output to the analog meter.

The sensor electronics are calibrated at the factory with the specific sensor being used in the equipment. None of the potentiometers on the two sensor electronics boards should be readjusted in the field. If there is a problem with either the sensor or the sensor electronics, call the factory. The fuse may be replaced without disturbing calibration.

The RUN/CAL switch on the board is used during the calibration procedure at the factory. In the CAL position, the Wheatstone bridge is bypassed and a constant signal is provided to the filament current amplifier. Generally in the CAL position, sensor current will be higher than in the normal RUN position. The switch **MUST** be in the RUN position (to the right) for normal operation.

APPENDIX A

TRIP POINT AND FUNCTION SWITCH SETTINGS

There are two 8-position dip (dual in-line package) switches on the main control board, see Appendix Diagram "A". Switch S1 is a function switch. Switch S2 is used to set the trip point for Alarm Mode.

S1 Function Switch

Positions 1 through 7

These positions are used to set parameters for communicating to external devices and computers. If you have one of these options, refer to the instruction literature provided with the option for information on how to set the switches. If you are not using the external communications capabilities, you can ignore positions 1 to 7. They do not affect any other function.

Position 8 Run/Test

Position 8 determines whether the unit is in Run Mode or Test Mode. Test mode is used for trouble shooting and maintenance. For normal operation the position 8 must be in run mode. Appendix Diagram "A" shows the switch in the run position.

S2 Trip Point

Switch 2 is used to set the trip Point, the ppm reading at which the unit will go into Alarm Mode. See the following page, Trip Point Settings display how to set the switch for a variety of refrigerant levels. The switch has been preset at the factory. There is a label on the inside front cover of the unit with the value of the preset trip point. If the switch setting is changed, note this change on the label inside the front panel of the unit to indicate the new trip point, when it was set, and who set it. This can be a big help in troubleshooting should a problem develop.

The switch essentially provides the computer with an 8 bit binary fraction of the full scale of the unit. For example if full scale of the monitor is 100 ppm, setting position 8 will be a trip point of 50 or half of full scale. Position 7 is one fourth of full scale, and so on down to position 1 which is one two hundred and fifty-fifth of full scale. By combining switches, it is possible to get any trip point required. For ease of use, it is suggested that you use the chart provided.

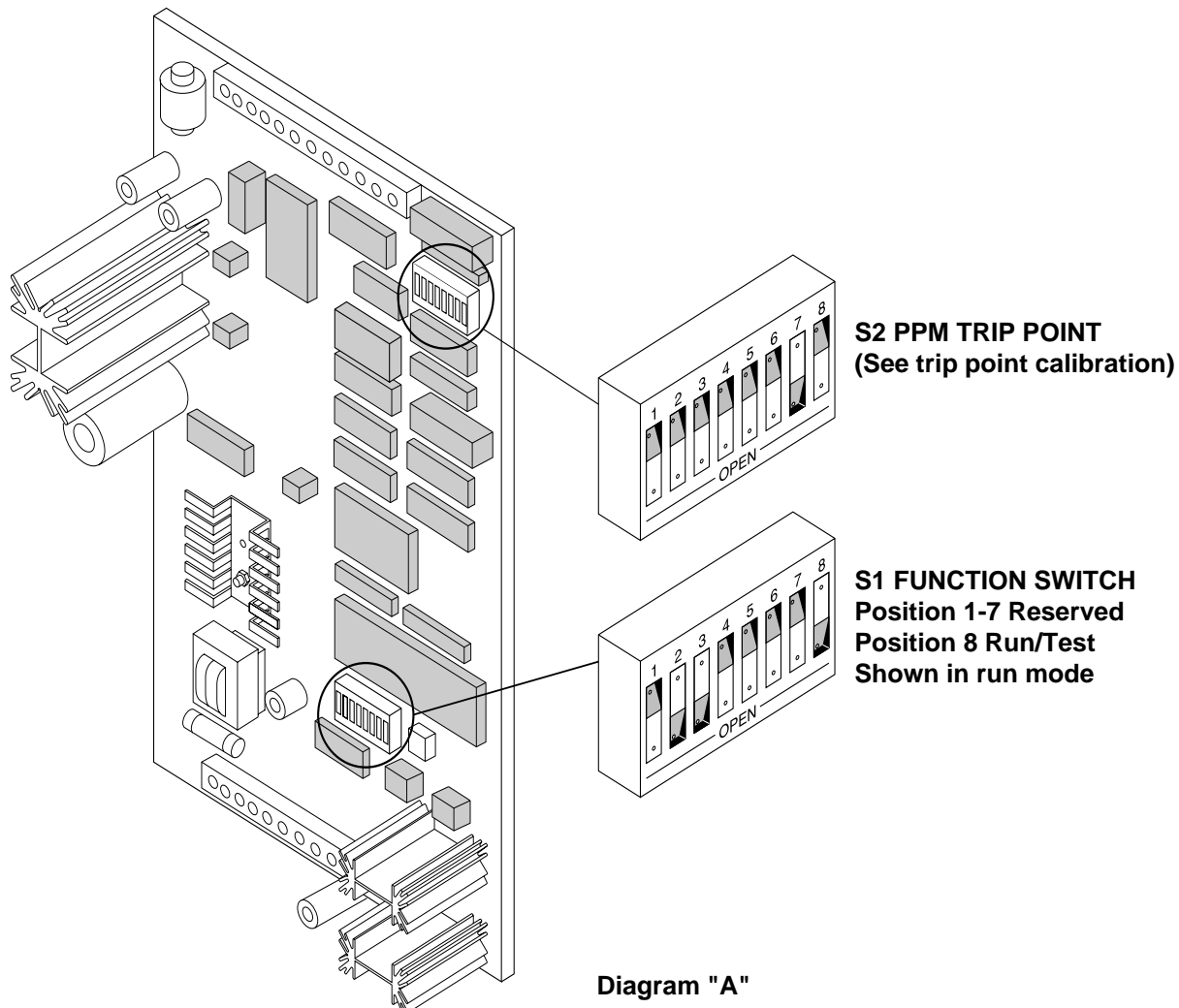

TRIP POINT SETTINGS 100 PPM FULL SCALE CALIBRATION †

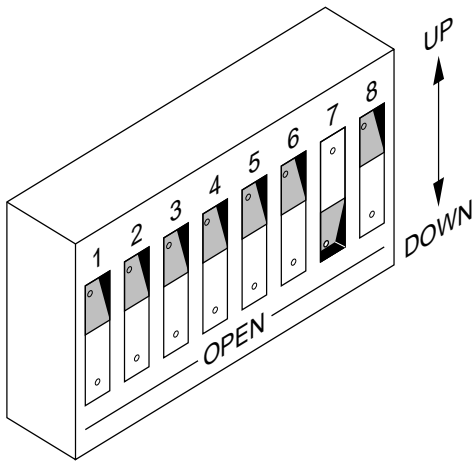
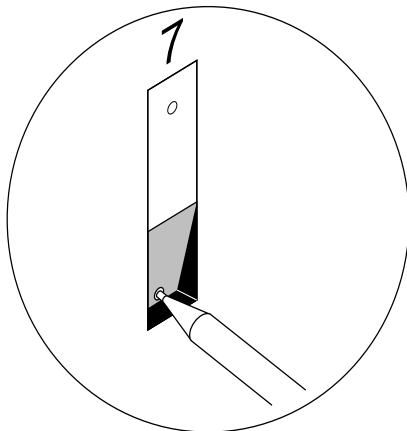

**FIGURE 1
TRIP POINT SETTING
@ PPM - 25
(DIP SWITCH - 7)**

PPM	DIP SWITCH DOWN
*0	NONE
5	1,3,4
6.75	5
10	1,4,5
12.5	6
15	2,3,6
20	1,2,5,6
25	7
30	1,3,4,7
35	1,4,5,7
40	2,3,6,7
45	1,2,5,6,7
50	8
60	1,4,5,8
70	1,2,5,6,8
80	3,4,7,8
90	2,3,6,7,8
*100	1,2,3,4,5,6,7,8

Not recommended
unless normal
ambient very high

*** DO NOT USE**



**FIGURE 2
USE A PENCIL OR FINE TIP PIN
TO SET THE SWITCHES
(ILLUSTRATION SHOWS SWITCH #7 DOWN)**

† For units with a range of 0-1000 PPM, multiply PPM values by 10.

APPENDIX B: SenTech Room Volume Considerations (English)

Normal industry practice is to think about refrigerant leaks in terms of pounds of refrigerant per unit time such as lbs/hr or ozs/yr. This is a natural and logical way of looking at it. The system monitors the amount of refrigerant present in the air in Parts Per Million (ppm) by volume of refrigerant molecules as compared to air molecules. In order to develop a relationship between the leak rate in weight per unit time and ppm reading of the monitor, there are a number of items that need to be considered and accounted for. These are:

1. Room Volume.
2. The relationship between refrigerant amount in weight compared to refrigerant volume at the temperature and pressure of the room.
3. The amount of time the refrigerant has been leaking.
4. The rate at which fresh air enters the room (stale air is exhausted).
5. The location of the monitor inlet relative to the leak, the air patterns of the room, and the rate at which the leaking refrigerant expands to fill the room.

For a given specific situation items 1 through 4 are either known, can be calculated, or can be estimated. Item 5 is virtually unknowable, therefore in all the formulas and sample calculations it is assumed that leaking refrigerant expands immediately to fill the room. This is a reasonable and conservative assumption on the basis that you have located the monitor following the recommendations outlined in the installation section. If you have followed those recommendations, the monitor should see a higher concentration sooner than the idealized formulas.

The equations have been developed for two cases. **Case I** is for a sealed room, no air turnover. **Case II** is for a room with a known turnover of air.

To be able to convert between a leak rate in cubic feet per hour to a leak rate in pounds per hour the molecular weight of the refrigerant needs to be known. If you know the molecular weight of the refrigerant, you can calculate the necessary conversion factors at normal atmospheric pressure and room temperature.

$$\frac{\text{Mol Wt(gms)}}{1(\text{mole})} \times \frac{1(\text{mole})}{22.4(\text{ltrs})} \times \frac{1(\text{pound})}{454(\text{gms})} \times \frac{28.32(\text{ltrs})}{1(\text{cuft})} \times \frac{273}{293} = \frac{\#}{\text{cuft}}$$

Substituting for R-22 which is 86.48 grams/mole, you get $0.22 \frac{\#}{\text{cuft}}$.

Conversion Factors for Common Refrigerants

R-22	.22 #/cuft	4.46 cuft/#
R-12	.31 #/cuft	3.18 cuft/#
R-11	.36 #/cuft	2.80 cuft/#
R-502	.29 #/cuft	3.45 cuft/#
R-123	.41 #/cuft	2.41 cuft/#

PPM READINGS AND LEAK RATE RELATIONSHIP DEFINITIONS:

- PPM = Monitor PPM reading or trip point PPM setting
- LR = Leak Rate of refrigerant in cubic feet per hour
- FA = Fresh Air into the room in cubic feet per hour
- VOL = Volume of the room in cubic feet
- t = Time in hours (There are 8760 hours in one year)
- R = Amount of refrigerant in the room in cubic feet
- LR_{min} = Minimum leak rate that will reach a given PPM

<p style="text-align: center;">Case I: Sealed Room</p> $\text{PPM} = \frac{\text{LR} \times t \times 10^6}{\text{VOL}} \quad t = \frac{\text{PPM} \times \text{VOL} \times 10^{-6}}{\text{LR}}$ $R = \text{PPM} \times \text{VOL} \times 10^{-6}$	<p style="text-align: center;">Case II: Room with Air Changing</p> $\text{PPM} = \frac{\text{LR}}{\text{FA}} \left(1 - e^{-\frac{\text{FA}}{\text{VOL}}t}\right) 10^6$ $t = \frac{\text{VOL}}{\text{FA}} \times \ln \left(\frac{\text{LR}}{\text{LR} - \text{PPM} \times \text{FA} \times 10^{-6}}\right)$ $\text{LR}_{\text{min}} = \text{PPM} \times \text{FA} \times 10^{-6}$
--	---

Sample Calculations (Assuming The room is 40 feet by 30 BY 10 feet = 12,000 cuft)

<p style="text-align: center;">Case I: Sealed Room</p> <ol style="list-style-type: none"> 1. How much refrigerant is necessary to cause a 25 ppm reading ? $R = 25 \times 12000 \times 10^{-6} = .3 \text{ cuft}$ If it is R-22: $.3 \text{ cuft} \times .22 \text{ lb/cuft} = .066 \text{ lbs}$ 2. If the leak rate is 300 lbs./year of R-22, how long will it take to reach 25 ppm ? $\frac{300 \text{ lbs}}{\text{yr}} \times \frac{1 \text{ yr}}{8760 \text{ hr}} \times \frac{4.46 \text{ cuft}}{\text{lbs}} = .153 \text{ cuft/hr}$ $t = \frac{25 \times 12000 \times 10^{-6}}{.153} = 1.96 \text{ hrs}$ 	<p style="text-align: center;">Case II: Room with Air Changing</p> <p>Assume the same room 12,000 cuft. Assume fresh air at 100 cfm or 6000 cuft/hr (1 air changes in 2 hour).</p> <ol style="list-style-type: none"> 1. What is the minimum leak that will reach 25 ppm ? $\text{LR}_{\text{min}} = 25 \times 6000 \times 10^{-6} = .15 \text{ cuft/hr}$ for R-22: $.15 \text{ cuft/hr} \times .22 \text{ lb./cuft} = .033 \text{ lbs/hr}$ or 289 lbs/yr 2. How long will it take to detect a leak of 500 lbs/yr of R-22? $500 \text{ lbs/yr} = .26 \text{ cuft/hr}$ $t = \frac{12000}{6000} \times \ln \left(\frac{.26}{.26 - 25 \times 6000 \times 10^{-6}}\right) = 1.72 \text{ hrs}$ 3. If the trip point is set at 10 ppm, what is the minimum leak rate of R-123 that will trigger the alarm ? $\text{LR}_{\text{min}} = 10 \times 6000 \times 10^{-6} = .06 \text{ cuft/hr}$ for R-123: $.06 \times .41 \text{ lbs/ft} = .0246 \text{ lbs/hr}$ or 215 lbs/yr 4. How long will it take to detect a leak of 300 lbs/yr of R-123 ? $300 \text{ lbs/yr of R-123} = .0825 \text{ cuft/hr}$ $t = \frac{12000}{6000} \times \ln \left(\frac{.0825}{.0825 - 10 \times 6000 \times 10^{-6}}\right) = 2.6 \text{ hrs}$
--	---

These numbers represent worst case conditons. With the monitor placed close to the potential leak points and on the "downwind" side of the air flow, the trip points are likely to be activated sooner.

APPENDIX B: SenTech Room Volume Considerations (Metric)

Normal industry practice is to think about refrigerant leaks in terms of weight of refrigerant per unit time such as kg/hr or kg/yr. This is a natural and logical way of looking at it. The system monitors the amount of refrigerant present in the air in Parts Per Million (ppm) by volume of refrigerant per volume of air. In order to develop a relationship between the leak rate in weight per unit time and ppm reading of the monitor, there are a number of items that need to be considered and accounted for. These are:

1. Molecular weight of the refrigerant.
2. Density of the refrigerant at the temperature of the room.
3. Room volume.
4. The rate at which fresh air enters the room.
5. The location of the monitor inlet relative to the leak, the air patterns of the room, and the rate at which the leaking refrigerant expands to fill the room.

For a given specific situation items 1 through 4 are either known, or can be calculated. Item 5 is virtually unknowable, therefore in all the formulas and sample calculations it is assumed that leaking refrigerant expands immediately to fill the room. This is a reasonable and conservative assumption on the basis that you have located the monitor following the recommendations outlined in the installation section. If you have followed those recommendations, the monitor should see a higher concentration sooner than the idealized formulas.

The equations have been developed for two cases. **Case I** is for a sealed room, no air turnover. **Case II** is for a room with a known turnover of air.

To be able to convert between a leak rate in cubic meters per hour to a leak rate in kilograms per hour the density of the refrigerant must be known. At normal atmospheric pressure and room temperature.

$$\text{DENSITY (kg/m}^3\text{)} = \frac{\text{Mol Wt(gms)}}{22.4(\text{ltrs})} \times \frac{273}{293} \times \frac{1(\text{kg})}{1000(\text{gms})} \times \frac{1000(\text{ltrs})}{1(\text{m}^3)}$$

As an example for R-22, Mol Wt = 86.48 gm/mole.
Therefore density = 3.59 kg/m³, or 0.28 m³/kg

Conversion Factors for Common Refrigerants

R-22	3.59 kg/m ³	0.28 m ³ /kg
R-12	4.96 kg/m ³	0.20 m ³ /kg
R-11	5.76 kg/m ³	0.17 m ³ /kg
R-502	4.64 kg/m ³	0.21 m ³ /kg
R-123	6.56 kg/m ³	0.15 m ³ /kg

PPM READINGS AND LEAK RATE RELATIONSHIP DEFINITIONS:

- PPM = Monitor PPM reading or trip point PPM setting
- LR = Leak Rate of refrigerant in cubic meter per hour
- FA = Fresh Air into the room in cubic meter per hour
- VOL = Volume of the room in cubic meter
- t = Time in hours (There are 8760 hours in one year)
- R = Amount of refrigerant in the room in cubic meters
- LR_{min} = Minimum leak rate that will reach a given PPM

Case I: Sealed Room

$$\text{PPM} = \frac{\text{LR} \times t \times 10^6}{\text{VOL}} \quad t = \frac{\text{PPM} \times \text{VOL} \times 10^{-6}}{\text{LR}}$$

$$R = \text{PPM} \times \text{VOL} \times 10^{-6}$$

Case II: Room with Air Changing

$$\text{PPM} = \frac{\text{LR}}{\text{FA}} (1 - e^{-\frac{\text{FA}}{\text{VOL}} t}) 10^6$$

$$t = \frac{\text{VOL}}{\text{FA}} \times \ln \left(\frac{\text{LR}}{\text{LR} - \text{PPM} \times \text{FA} \times 10^{-6}} \right)$$

$$\text{LR}_{\text{min}} = \text{PPM} \times \text{FA} \times 10^{-6}$$

SAMPLE CALCULATIONS (ASSUMING THE ROOM IS 15 METERS BY 10 METERS BY 3 METERS = 450 CUBIC METERS)

Case I: Sealed Room

1. How much refrigerant is necessary to cause a 25 ppm reading ?
R = 25 x 450 x 10 = .0011 cubic meter
If it is R-22:
Amount of refrigerant = .0011 m³ x 3.59 kg/m³ = .004 kg
2. If the leak rate is 150 kg/year of R-22, how long will it take to reach 25 ppm ?
$$\frac{150\text{kg}}{\text{yr}} \times \frac{1 \text{ yr}}{8760 \text{ hr}} \times \frac{.28 \text{ m}^3}{\text{kg}} = 0.0048 \text{ m}^3/\text{hr}$$

$$t = \frac{25 \times 450 \times 10}{0.0048} = 2.35 \text{ hrs}$$

Case II: Room with Air Changing

- Assume the same room (450 m³).
Assume fresh air at 225 m³/hr (1 air changes in 2 hour).
1. What is the minimum leak that will reach 25 ppm ?
LR_{min} = 25 x 225 x 10 = 0.0056 m³/hr
for R-22:
0.0056 m³/hr x 3.59 kg/m³ = 0.02 kg/hr OR 175 kg/yr
 2. How long will it take to detect a leak of 200 kg/yr of R-22?
200 kg/yr = 0.023 kg/hr
$$t = \frac{450}{225} \times \ln \left(\frac{.023}{.023 - 25 \times 225 \times 10^{-6}} \right) = 4.0 \text{ hrs}$$
 3. If the trip point is set at 10 ppm, what is the minimum leak rate of R-123 that will trigger the alarm ?
LR_{min} = 10 x 225 x 10 = .00225 m³/hr
for R-123: .00225 x 6.56 kg/m³ = .0148 kg/hr OR 130 kg/yr
 4. How long will it take to detect a leak of 150 kg/yr of R-123 ?
150 kg/yr of R-123 = .0026 m³/hr
$$t = \frac{450}{225} \times \ln \left(\frac{.0026}{.0026 - 10 \times 225 \times 10^{-6}} \right) = 4.0 \text{ hrs}$$

These numbers represent worst case conditons. With the monitor placed close to the potential leak points and on the "downwind" side of the air flow, the trip points are likely to be activated sooner.

SenTech System 2000 Exploded View & Parts List

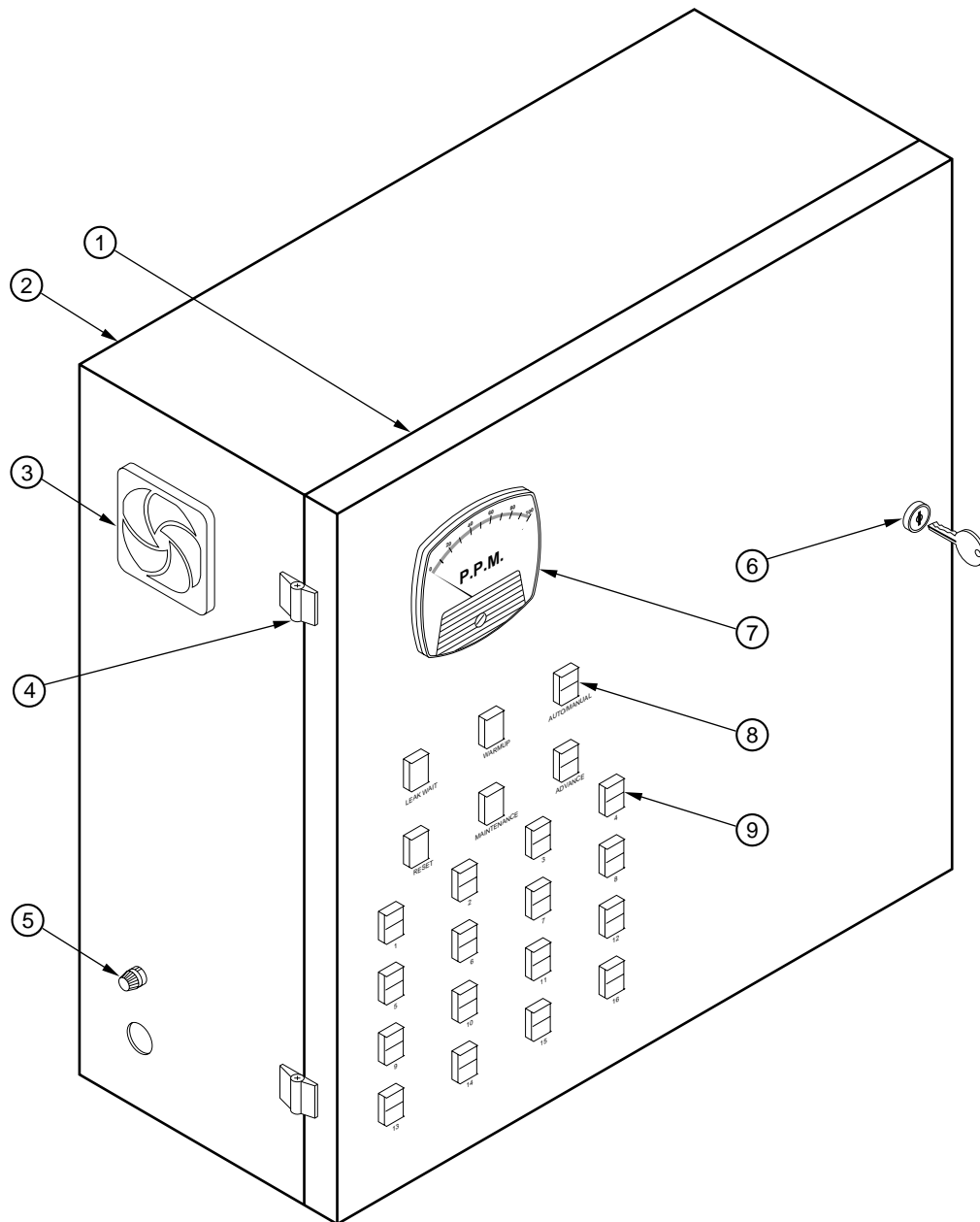

1. Lid, Finished	400005	11. Terminal Strip,		20. Pressure Switch	410106
2. Box, Finished	400006	7 position	410041	21. Transformer	410039
3. Fan Guard/Filter	410017	12. Main Power Fuse	410095	22. Vacuum Pump	
Filter Replacement	410018	Main Power		Assembly (115 VAC)	410107
4. Hinge (2)	410050	Fuse Holder	410033	Vacuum Pump	
5. Main Power Fuse	410095	13. Relay, 24 VDC (3)	410087	Assembly (240 VAC)	410108
Main Power		Relay Socket (3)	410040	23. Sensor*	
Fuse Holder	410033	14. PLC Base Unit	410092	Sensor Bracket	400056
6. Key Lock Assembly	410006	15. 5 Micron Filter	410122	24. Flowmeter	410121
7. Meter, Analog	410010	5 Micron		Flowmeter Bracket	400057
8. Push Button		Replacement Element	410162	25. Control Board*	
Switch (6)	410153	16. PLC Extension Unit	410093	26. Fan Guard/Filter	410017
9. Panel Light (16)	410154	17. Pressure Gauge	410120	Filter Replacement	410018
Replacement Lamp		18. PLC Extension Unit	410093	27. Manifold Assy. (4)	410114
(24VDC)	410159	19. Power Supply		28. Male Connector (16)	410123
10. Exhaust Fan	410016	(24 VDC)	410104	29. Pressure Relief	410130

* Replacement of the sensor, or control board requires recalibration. Return to the factory for repair.

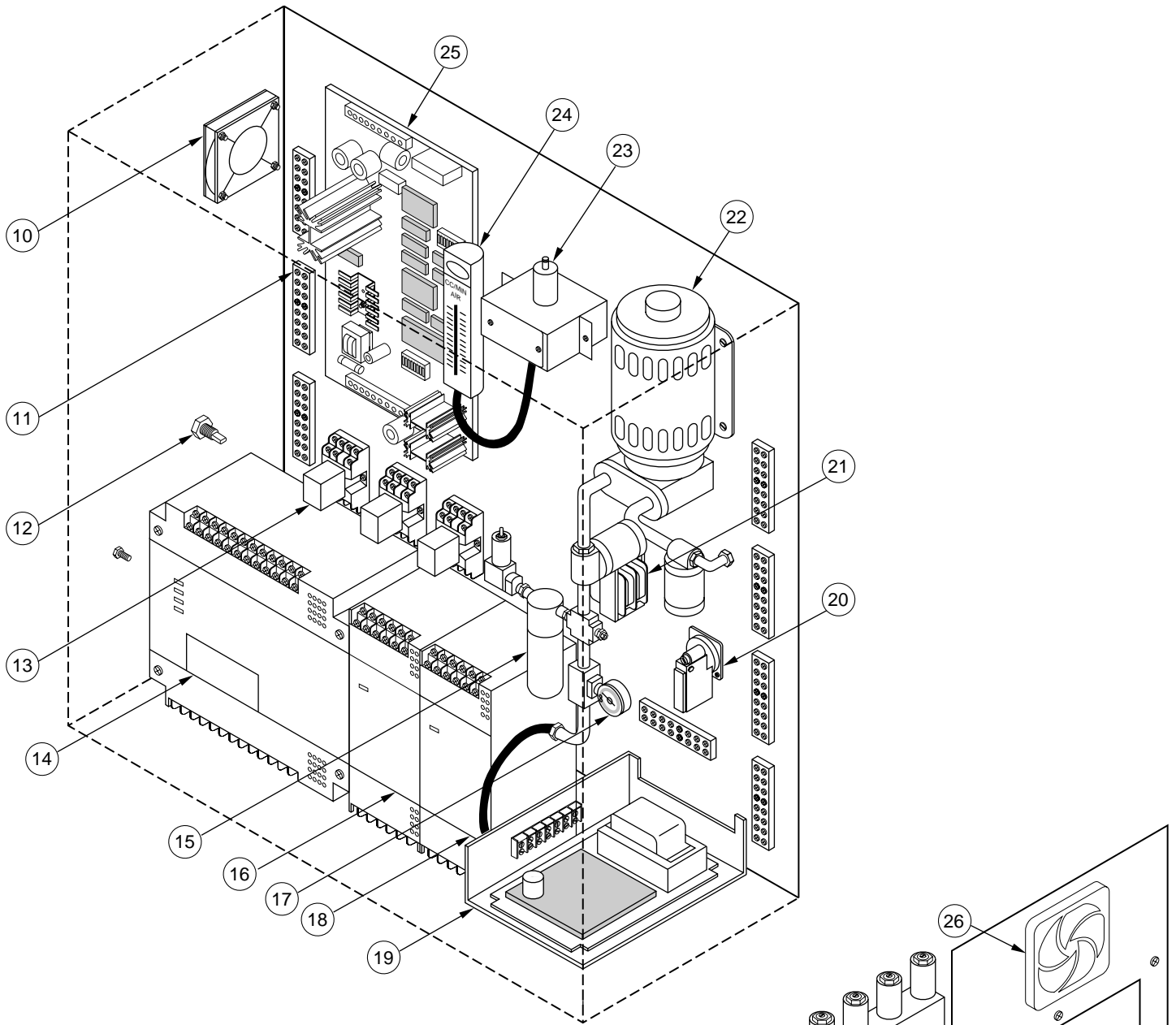

ITEMS NOT ILLUSTRATED

- Course Tube Filter 410144
- Female Hose Barb 1/4" 410151

OPTIONAL EQUIPMENT

- Alarm, Visual Strobe 410061
- Alarm, Audible Horn 410062
- Alarm, Combination
Horn/Strobe 410036
- Digital Display Meter 410096
- Tubing, 3/8" O.D. 410109
- Tubing Splice Fitting 410196
- 20 Micron Filter Assembly 410161
- 20 Micron
Replacement Element 410163

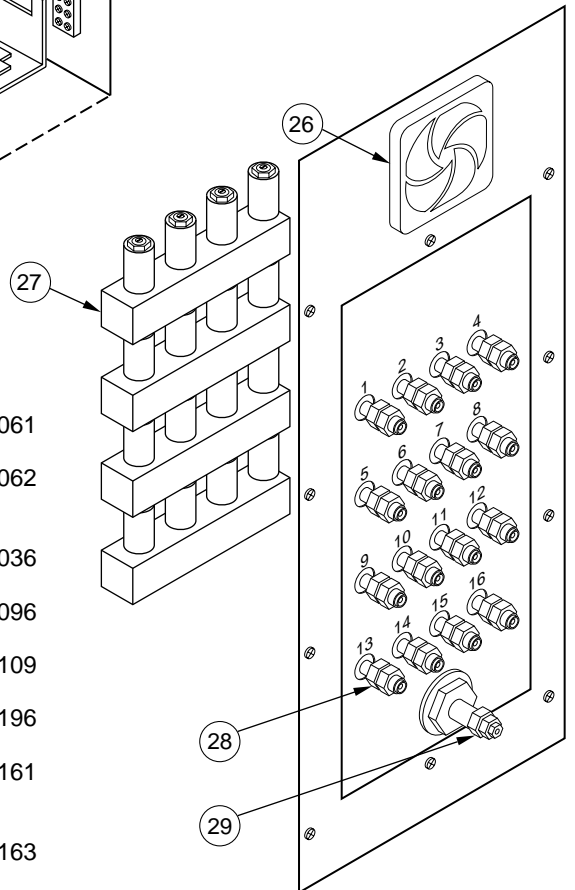

Troubleshooting Guide

Before starting, refamiliarize yourself with the START-UP section of the manual (page 6). For a more detailed discussion of the operation and maintenance of the various subsystems, refer to the MAINTENANCE AND TROUBLE SHOOTING section starting on page 9. Depending on the problem, you may need to prepare a sample of refrigerant to use in testing. You should also check the appendix on setting the trip point and function switches. Certain of these tests will require the use of a volt/ohm multimeter.

If you determine that there is a problem in the main control board, the unit should be recalibrated, after replacement.

Symptom	Remedy
1. No lights, pump not running, PLC deenergized.	<ol style="list-style-type: none">1. Check fuse F1, replace with 5 amp slo blo if failed.2. Check for 120 volts AC incoming power at pins 1 and 4 of TBP.
2. No lights, pump running.	<ol style="list-style-type: none">1. Push the Maintenance push-button. If the even and odd zone alarm lights flash, the Automatic lamp and one or more zone lamps have failed.2. Check for 24 Volts DC at the "+" and "-" pin of the power supply terminal board. If no 24 Volts, check for 120 Volts AC at pins 1 and 4 of the power supply terminal board.<ol style="list-style-type: none">a. If AC voltage is present, replace the power supply.b. If there is no AC voltage, trace the AC wiring from the power supply through the maintenance relay to the incoming power point.
3. Maintenance light lit, no zone alarm lights flashing.	<p>This indicates a failure in the pneumatic system. (Refer to page 9 for a detailed description of pneumatic system failures.)</p> <ol style="list-style-type: none">1. Push the Reset push-button. If the pump does not start operating, replace the pump.2. If the pump runs and does not shut off after 10 or 15 seconds.<ol style="list-style-type: none">a. Using the Advance push-button, slowly cycle through all the zones. If the pump continues to work ok in each zone, there may have been a transient event. Continue to monitor the system for several days to see if there is a recurrence.b. If system goes into maintenance in one or more of the zones, there is likely to be a blockage in the tube run in those zones. Check the tube runs and the coarse filter.3. If the pump runs and shuts off after 10-15 seconds and the maintenance light comes back on. Disconnect the tubing from zone 1. Using the Advance push-button move to zone 1 and put the system in Manual. Press Reset.<ol style="list-style-type: none">a. Check the pressure gauge, if it is reading less than 2 psi, reset the pressure relief valve to 4 PSI (see fig. 6 on page 10). To reset the pressure loosen locking nut and turn the valve.b. If the back pressure is ok, the pressure switch may be out of adjustment or it has failed. Turn the adjustment screw on the pressure switch counterclockwise. If that does not solve the problem, the pressure switch has likely failed. See the discussion on page 10 for resetting sensor air flow.

Symptom

Remedy

4. Maintenance light lit, all zone alarm lights flashing.

1. When all zones go into alarm, the system shuts down and stops sampling to protect the sensor. If there has been a major leak and all the pickup points are in the same room or connecting rooms with air flow between them, it is possible that all the zones did detect a leak. Reset the system and see if you can pinpoint which zone has the leak.

If after careful checking, you do not believe there was a leak, Go to Symptom 7, System has gone into alarm and it believed there is no leak.

5. Controls not responding normally suspected PLC or PLC program failure.

1. If you suspect a problem with the PLC or the program, refer to the discussion on page 11 for a detailed description of the PLC.

a. Remove power from the system and then repower it. This will reset the PLC and reread the program from EPROM memory.

b. Check the green RUN LED on the main PLC unit. If it is not lit. Check for the jumper between PLC 24V and RUN.

c. If neither a or b solve the problem. Check the wiring to the PLC for loose connections.

6. Failure to detect a leak/suspected low sensitivity.

1. The system is in Manual mode and is not on the zone where there was a suspected leak. Switch to Automatic so that the system will scan all selected zones.

2. The zone alarm light is flashing indicating an alarm, but the external alarm devices (horns, lights etc) are not actuated.

a. Check for 24 Volts DC at the alarm relay coil between pin13 and pin14. If no voltage, check that the Y3 output of the LED is energized. IF the PLC output is on, check for loose wiring. If the PLC output is off, the PLC may have failed.

b. There is voltage at the relay, check that the relay is energized by testing for continuity at an unused set of normally open contacts. If the relay is not energized, replace it.

c. If the relay is energized, check the wiring to the external devices and check the devices themselves.

3. Check the trip point setting of the unit to make certain that it has not been set too high. Typical trip points should be 30 PPM or less. (see Appendix A). If the trip point is too high, reset and repeat steps 4 through 9 of the startup procedure to confirm proper operation (see page 7).

4. If 1 through 3 have not uncovered the problem, repeat steps 4 through 9 of the startup procedure. There has been a failure in the control board or sensor. Try replacing the sensor, and repeating the startup procedure. If that does not solve the problem, it is likely that the control board has failed. Replace the board and calibrate the unit following the instructions in the Calibration Section of the manual.

5. If all the checks indicate the unit is operating properly, yet it is still believed that a leak was not detected by the system. Review the location section of the installation procedure. It may be that the pick up points are not located appropriately, or that there is a break in the zone tubing runs.

Symptom

Remedy

7. System has gone into alarm and it is believed there is no leak.

1. Depress the Reset push-button and wait for completion of the warmup period. If the system does not go into alarm, repeat steps 4 through 9 of the startup procedure (see page 7). If the unit appears to operate normally, there may have been a transient phenomenon that caused the alarm. Some examples are:

Someone using a halogen based degreaser such as trichloroethylene near the system.

A leaky purge that is not properly vented.

Monitor the system closely for the next several weeks to see if it continues to operate normally.

2. If after warmup, the system goes into alarm yet the meter reading was very low, Check that the trip point has not been changed to 0 PPM or a very low value (see Appendix A). Reset the trip point to an appropriate value, and recheck as in step 1. above.

3. If after warmup the meter is in fact high, there are three possibilities:

a. There is a leak in the refrigerant system.

b. There is a high ambient level of halogen based hydrocarbons, that may be the result of chemicals stored in the room (such as a leaking refrigerant cylinder).

c. The unit has failed.

One way of testing for failure is to run tubing from one of the zones to a room that you are absolutely sure could not have any halogens present (or outside). If you still have a high reading, it is likely the sensor has reached end of life or failed. Replace the sensor. If that does not solve the problem, the control board has failed. Replace the board and calibrate the unit following the instructions in the Calibrations section of the manual.

CALIBRATION PROCEDURE

INTRODUCTION

There are generally two reasons to recalibrate a SenTech refrigerant monitor. To confirm proper system operation, or after a repair that may have affected the calibration. If the recalibration is the result of a repair, make certain that all system functions are operating properly, before proceeding with the recalibration.

Calibration is achieved by inserting an appropriate calibration gas to the input of the sensor, and setting system gain so that the Parts Per Million (PPM) reading matches that of the gas.

MATERIALS REQUIRED

1. A cylinder of calibration gas with a regulator and output fitting. The calibration gas analysis should be as follows.

a) 0 to 100 PPM models (Those used for CFC's or HCFC's)

20 PPM of the refrigerant and the remainder clean dry air.

b) 0 to 1000 PPM models (Those used for HFC's)

200 PPM of the refrigerant and the remainder clean dry air.

(In a later section of this manual information on sources of calibration gas is provided.)

2. A short length of 1/4" OD, 1/8" ID plastic tubing.

3. A small slotted head screwdriver.

4. The Instruction Manual for the monitor (while not essential, the manual can be useful in locating the proper insertion point for the specific model).

CALIBRATION PROCEDURE

1. If the monitor has been shut off for more than a day, allow it to warm up for several hours before calibrating. If it has been shut off for only an hour or two, allow it to warm up at least ten or fifteen minutes.

2. Set position 8 of SW1 on the control board in the Test Mode. Depressed towards the top of the switch. (See figure 1, or Appendix A of the Instruction Manual). Test Mode bypasses the alarm circuitry.

BE SURE TO RETURN SW1 TO THE RUN POSITION WHEN YOU ARE FINISHED CALIBRATING THE UNIT.

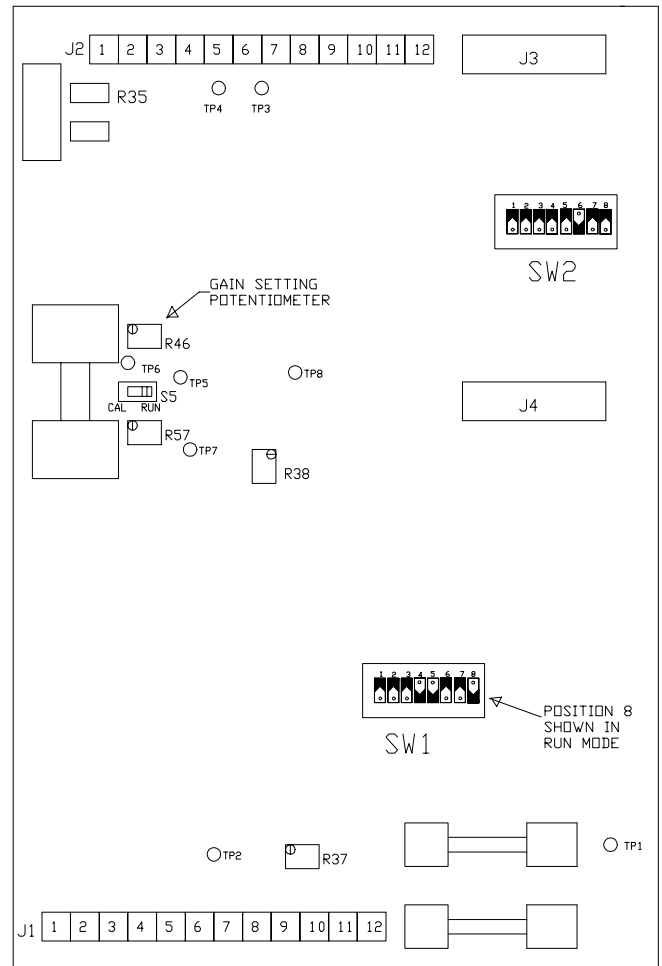
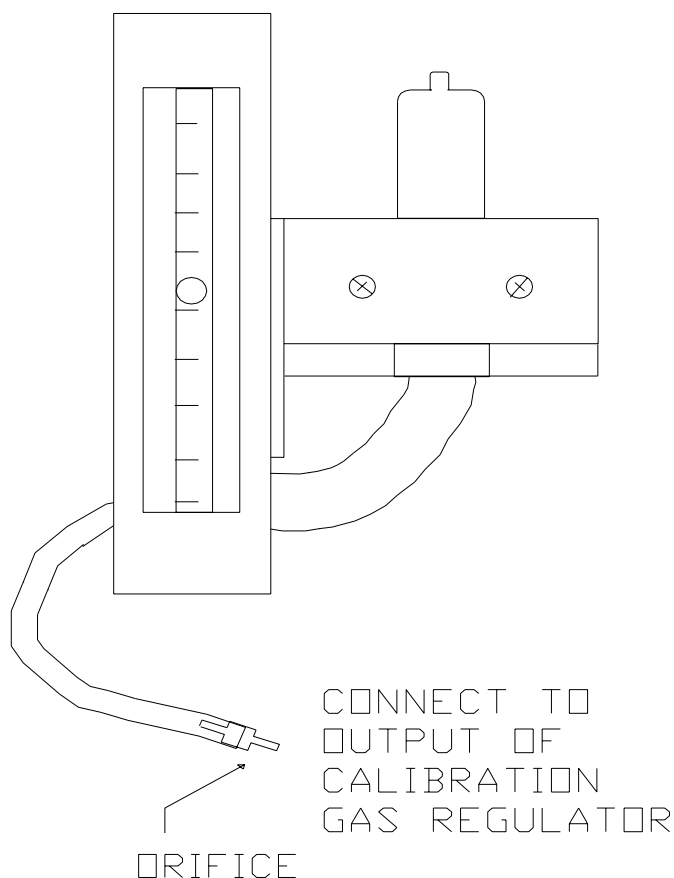

FIGURE 1.
CONTROL BOARD LAYOUT

3. Check and make a note of the flowmeter reading. Compare the reading to the flow noted on the decal on the inside of the lid of the unit.

(If the flowmeter reading is more than 50 cc/min below the amount noted on the decal, refer to the instruction manual of the unit. There may be a dirty filter, a plugged orifice, or some other pumping system problem, which should be corrected before proceeding.)

4. Disconnect the pumping system from the flowmeter at the orifice. (See Figure 2.)



5. Connect the tube from the calibration gas cylinder to the input of the orifice.

6. With the cylinder regulator set at 0 psi, slowly open the cylinder valve.

7. Adjust the regulator so that the flowmeter reading is within 20 cc/min of the reading noted above.

This will take a bit of patience and care. The longer the tubing run, the longer it will take the system to react to changes in pressure setting.. Make small changes and wait to see the affect.

8. Adjust the gain setting potentiometer R46 until the PPM reading matches the calibration gas PPM. Note: clockwise reduces gain.

As with 7 above, this probably take 2 or 3 adjustments. Keep in mind that ambient air was in the tube from the cylinder. It will take some time to flush out the ambient air and have pure calibration gas flowing through the sensor.

9. Close the cylinder valve and disconnect the tube from the calibration gas cylinder to the orifice.

10. Reconnect the orifice to the unit's pumping system.

11. Reset position 8 of SW1 to the run position (depressed at the bottom, refer to fig 2)

DO NOT LEAVE THE UNIT IN TEST MODE IT WILL NOT ALARM IF THERE IS A LEAK.

12. Calibration is now complete and the unit can be returned to operation.

GENERAL COMMENTS AND GUIDELINES

Multiple Refrigerants

One of the advantages of SenTech monitors is their ability to monitor for more than one type of refrigerant. Since the unit can only be calibrated for a single refrigerant type, the following criteria should be used in selecting the refrigerant to use:

1. Always use R123 if that is one of the refrigerants being monitored. R123 has a lower AEL (Acceptable Environment Level) than all other common refrigerants. Therefore it is more important that its Alarm Point be accurate.

2. Although the SenTech monitor will detect all halogen based refrigerants, its sensitivity does vary with refrigerant type. The commonly used refrigerants can be segregated into four groups, from the most sensitive (highest reading for a given concentration) to the least sensitive (lowest reading).

Most sensitive	R11, R22, R123
Moderately sensitive	R502
Lower Sensitivity	R12, R500, R114
Least Sensitive	R134, and other HFC's

Choose the refrigerant with the lowest sensitivity. For example, if the unit is monitoring a room that has both R12 and R22, choose R12 for the calibration gas.

Why Use a Calibration Mixture at 20% of Full Scale?

SenTech monitors are early warning devices. Their function is to alert the user to refrigerant leak as soon as

possible. To best accomplish their intended function, the alarm point is set as low as possible without incurring nuisance alarms. Therefore, it is desirable to have the greatest accuracy, at the lower end of the operating range.

Sources of Calibration Gas

Calibration gases can be purchased from a number of specialty gas suppliers. One supplier we can recommend is:

Scott Specialty Gases Inc.
1290 Combermere St.
Troy, MI 48083

Phone 810-589-2950
FAX 810-589-2134

"ROUGH" CALIBRATION IF THERE IS NO CALIBRATION GAS AVAILABLE.

If a control board has been replaced and there is no calibration gas available, the following procedure will bring the unit to the approximate operating range. Although the PPM readings may be off by 20 to 30%, the rough calibration allow you to put the unit back on line and detecting for refrigerant leaks.

1. If there is a cylinder of clean dry air or nitrogen available, connect it to the orifice as described in steps 1 through 7 of the calibration procedure above.

OR

if there is no clean air or nitrogen available

1a. Put the unit in Manual and select a zone that you are confident has no refrigerant present. One way would be to temporarily attach tubing to the selected zone and run it to a room that has no refrigerant using units in it.

2. Set position 8 of SW1 on the control board in the Test Mode. Depressed towards the top of the switch (see figure 1).

3. Attach a DC Voltmeter to TP1 and TP8 of the control board.

4. **IF ALL THE REFRIGERANTS BEING MONITORED CONTAIN CHLORINE ATOMS (CFC'S, OR HCFC'S)** adjust the gain setting potentiometer R46 until the voltmeter reads approximately 50 to 60 milliVolts dc (0.05 to 0.06 Volts dc).

OR

4a. **IF ANY OF THE REFRIGERANTS BEING MONITORED CONTAIN FLUORINE ONLY (HFC'S)** adjust the gain setting potentiometer R46 until the voltmeter reads approximately 150 to 160 millivolts dc (0.150 to 0.160 Volts dc).

5. Disconnect the cylinder if you used one and reconnect the orifice to the pumping system. Or put the zone tubing back to the original configuration.

6. Reset position 8 of SW1 to the run position (depressed at the bottom).

DO NOT LEAVE THE UNIT IN TEST MODE IT WILL NOT ALARM IF THERE IS A LEAK

7. The rough calibration is now complete. Remove the voltmeter and put the unit back in Automatic mode.



SenTech, gives the following as its complete Limited Warranty Statement:

**SenTech
Manufacturer's Limited Warranty**

SenTech warrants to the original purchaser-user that its equipment, as originally supplied, is free from defects in materials and workmanship and will perform adequately under normal use and service, subject to the following conditions and limits:

If the equipment or any part or parts thereof prove to be defective in normal use, then such item or parts will be repaired or replaced at the option of **SenTech** by **SenTech**, provided that notice of such defect is given by original purchaser-user to **SenTech** within one (1) year from the date of original installation of the equipment.

Warranty is made on condition that such original purchaser-user has returned to **SenTech** the warranty registration form applicable to the equipment, duly and fully completed, within thirty (30) days of the date of purchase by the original purchaser-user.

SenTech's obligation under this warranty is limited exclusively to replacing without charge, or to repairing, at **SenTech's** option, upon return to Indianapolis, Indiana, transportation charges prepaid, any part or parts that shall be found to be defective in material or workmanship during the warranty period. Charges for labor (except for labor performed by **SenTech** factory for repairing defective parts) are not covered and these, plus all other costs and expenses for transportation, insurance, etc., shall be paid for by the Warrantee. If, upon inspection by **SenTech** or its Authorized Service Representative, it is determined that the equipment has not been used in an appropriate manner as described in the **SenTech** Operator's Manual or has been subject to misuse, alteration, accident, damage during transit or delivery, or that such part is from a machine on which the serial number has been altered or removed, then this warranty is void and of no further force or effect. All decisions regarding the existence of defects in material or workmanship or other causes shall be made by **SenTech's** Factory Representative and shall be final and binding upon the parties. Returns shall only be made upon the prior written authorization thereof by **SenTech**.

THE FOREGOING LIMITED WARRANTY IS EXPRESSLY MADE IN LIEU OF ANY AND ALL OTHER WARRANTIES, EXPRESS OR IMPLIED, INCLUDING WITHOUT LIMITATION ANY IMPLIED WARRANTY OF MERCHANTABILITY OR FITNESS FOR A PARTICULAR PURPOSE.

The foregoing limited warranty shall not be enlarged or affected by, and no liability or obligation shall arise from, **SenTech's** rendering of technical or other advice, or service, in connection with any of its equipment or parts. Employees, agents, distributors, retailers, and sales representatives are not authorized to make warranties. Oral or written statements made may they do not constitute warranties and shall not be relied upon.

REPLACEMENT OR REPAIR OF DEFECTIVE EQUIPMENT OR PARTS AS PROVIDED ABOVE IS THE ORIGINAL PURCHASER-USER'S SOLE AND EXCLUSIVE REMEDY FOR CONTRACT, WARRANTY, NEGLIGENCE, TORT OR STRICT LIABILITY CLAIMS FOR ANY LOSS, DAMAGE OR EXPENSE ARISING OR ALLEGED TO ARISE OUT OF THE DESIGN, MANUFACTURE, SALE, DELIVERY OR USE OF SUCH EQUIPMENT AND/OR PARTS. IN NO EVENT SHALL SENTECH BE LIABLE FOR ANY AMOUNT IN EXCESS OF THE PURCHASE PRICE OF THE EQUIPMENT, OR FOR LOSS OF USE OR PROFITS, LOSS OF BUSINESS INTERRUPTION, ATTORNEY'S FEES, OR CONSEQUENTIAL, CONTINGENT, INCIDENTAL OR SPECIAL DAMAGES CAUSED OR ALLEGED TO CAUSED IN WHOLE OR IN PART BY THE NEGLIGENCE, TORT, STRICT LIABILITY, BREACH OF CONTRACT, BREACH OF WARRANTY, OR OTHER BREACH OF DUTY OF OR BY SENTECH.

SenTech
5745 Progress Road
Indianapolis, Indiana 46241

THIS LIMITED WARRANTY IS NOT TRANSFERABLE.

Warranty Information

Remove the Check Test Start (CTS) form from the pocket of this manual and fill it out in its entirety. Return the original (top) copy to SenTech by folding as instructed on the reverse of copy. Dealer/Distributor retain second copy and Owner/Operator retain third copy.

Replacement Parts

When ordering replacement parts, specify the part numbers, give the description of the part, the model number and the serial number of the machine.

Parts Order Procedure

1. Order on your purchase order letterhead.
2. Specify shipping instructions. If any order is received without specific shipping instructions, the order will be shipped best way.
3. Indicate the quantity desired, the part number, and the part description.
4. Always indicate the model number and the serial number of the machine for which the part is being ordered. In the back of this manual is an exploded view drawing and parts list of your SenTech machine. This will assist in ordering parts.
5. Regular mailed orders normally take three (3) days to process and ship.
6. All prices are subject to change without notice.
7. All shipments are made f.o.b. Indianapolis. By acceptance of a package, the carrier assumes liability for its deliveries to the customer in good condition. If a package is lost or damaged, immediately file a claim with the carrier, not SenTech.

Parts Return Procedure

1. No warranty parts shall be returned to SenTech without written authorization from the factory parts department.
2. When any part is returned to SenTech for any reason, such part must be properly identified.
3. Parts returned without proper identification will be kept for a reasonable period of time and disposed of as seen fit. In such cases, no credit will be issued.
4. Nondefective parts will be returned to the customer at the customer's expense.
5. If a letter is written pertaining to any refund part, this letter should be attached to the package containing part.
6. All correspondence pertaining to parts must be directed to the SenTech Parts Department at:

SenTech
5745 Progress Road
Indianapolis, Indiana 46241
7. All parts are sold f.o.b. factory.
8. Parts returned "collect" will be refused by our shipping department.

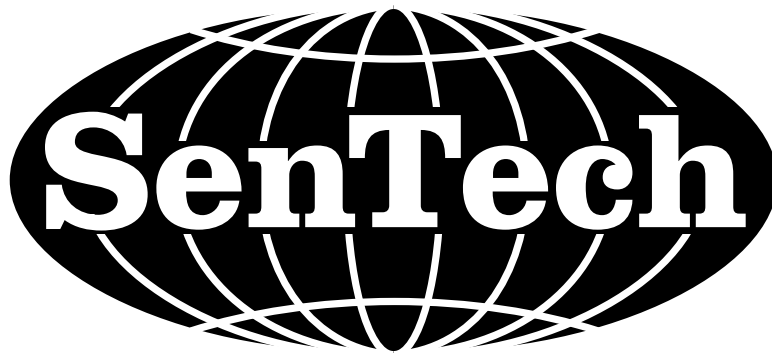

P/N 400203
Rev. 10/09/95
prepared for NASCO

