

INSTALLATION AND OPERATION MANUAL ENVIRONMENTAL SYSTEM SSG MODELS SSG1, 4, 8

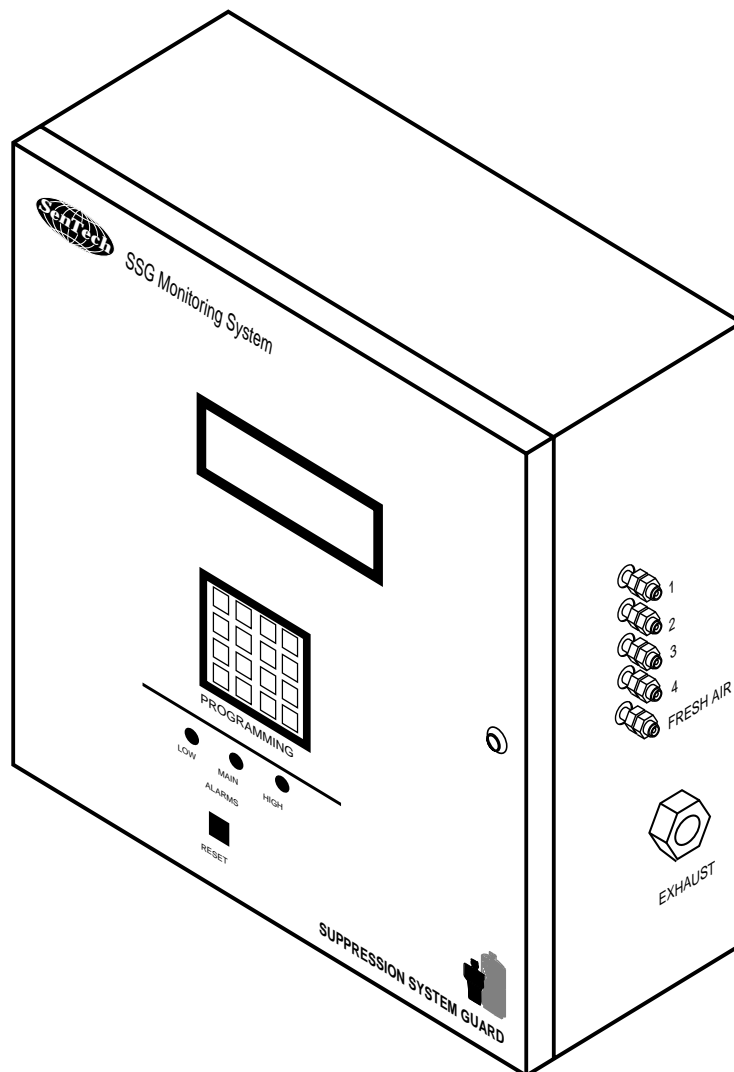

SenTech Corporation
5745 Progress Road
Indianapolis, Indiana 46241
888/248-1988
FAX 317/248-2014

Contents

SAFETY PRECAUTIONS and WARNINGS	3
SPECIFICATIONS	4
INTRODUCTION/OVERVIEW	5
Basic Concept	5
Sensitivity	5
INSTALLATION	6
Location	6
Mounting and Tuging Installation	6
Primary Power	6
OPTIONAL CONNECTIONS	8
Alarm Relay Contacts	8
Analog Outputs	8
START-UP	8
Setup	8
Final Check	9
SYSTEM OPERATION	10
PREVENTIVE MAINTENANCE	11
APPENDIX A	12
Programming and Operator Interface	12
APPENDIX B	15
Room Volume Considerations (English)	15
Room Volume Considerations (Metric)	16
EXPLODED VIEW & PARTS LIST	17
WIRING DIAGRAM	18
TROUBLESHOOTING GUIDE	19
WARRANTY	21
ILLUSTRATIONS	
Fig. 1 Block Diagram	5
Fig. 2 Primary Power Wiring Diagram	6
Installation Layout	7
Fig. 3 Alarm Relay Option Wiring	8
Fig. 4 Analog Output	8
Fig. 5 Front Panel	10

SAFETY PRECAUTIONS and WARNINGS

The following general safety precautions and warnings must be observed during all phases of installation, operation, service and repair of the equipment. Failure to comply with these precautions, given here and elsewhere in the manual violates safety standards of design, manufacture, and intended use. SenTech assumes no liability for the customer's failure to comply with these requirements.

Definitions of safety symbols used on equipment and in manuals.

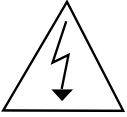

AC Voltage Terminal: Indicates areas of the equipment where AC line voltages are used and present a potential risk of electrocution. Areas using line voltages should not be accessed during operation.



Protective Grounding Terminal: The protective ground is to prevent electric shock in case of an electrical fault. This symbol indicates that the terminal must be connected to earth or ground before operation of the equipment.



Caution: This sign calls attention to a procedure or practice which if not adhered to could result in damage or destruction to a part of the product.

Input Power: Power should be supplied through a two pole circuit breaker located in reasonable proximity to the equipment. Ensure that the voltages are correct and an appropriate ground connection is provided.

Installation, Maintenance, and Repair: These functions should only be done by qualified personnel following the instructions outlined in this manual. This is Installation Category III equipment.

Pollution Degree: This equipment is designed for a Pollution Degree of 1.

Cleaning: The equipment should be cleaned by wiping with a soft clean cloth.

Intended Purpose: This equipment is designed to be used as a continuous monitor for halogen based fire suppression agents and refrigerants. It should not be used for any other purpose.

Models SSG1, 4, 8 Specifications

Size:	16 1/2" X 15" X 6 3/4" (42 cm X 38.1 cm X 17 cm)
Weight:	30 lbs (13 kgs)
Power:	120/240 Volt (+/- 10%) 50/60 Hz (41 Watts)
Temperature:	32° - 125° Fahrenheit, (0° - 50° Centigrade)
Humidity:	0 - 95% non-condensing
Atmospheric:	75 - 106 KPa
Pressure	Equipment rated for indoor use only
Range:	0 - 1000 P.P.M. Standard
Tube Length	0-250 ft. (76 meters)
Rezeroing	Automatic Standard
Zones	Model SSG1 - 1 Model SSG4 - 1 to 4 Programmable Model SSG8 - 1 to 8 Programmable
Trip Point:	Low Alarm 0 -100% of Full Scale Main Alarm 0 - 100% of Full Scale High Alarm 0 -100% of Full Scale
Leak Wait:	Varies from seven (7) seconds to three (3) minutes depending on refrigerant concentration
Alarm Output:	Low, Main, and High Alarm Relays Four (4) form C contacts rated 5 amps maximum
Analog Out:	0 to 10 VDC Standard 4 - 20 ma Optional

INTRODUCTION/OVERVIEW

The SenTech Suppression System Loss Prevention Monitors, Models SSG-1, 4, and 8 provide an early warning of developing gas leaks. The unit sequentially samples the ambient air in each selected zone and measures the amount of halogen based gas in the air sample. When the proportion of gas present exceeds a trip point, the system goes into Alarm Mode notifying the user. By discovering a leak shortly after it starts, the potential loss can be reduced to ounces of gas saving money and guarding against the unavailability of the system.

Basic Concept

Refer to the Block Diagram, (Fig. 1). Tubing from each area to be monitored is connected to the input manifold. The electronics sequentially energize the solenoid valves for each zone. The diaphragm pump draws air from the selected zone through the 5 micron filter assembly, the orifice, the infrared bench, and then to the exhaust port. The solid arrows show the air flow for normal operation.

The Infrared Bench has a source of IR energy at one end and a filter/detector at the other. Any Halogen based gas present in the sample air will cause a decrease in the output of the detector. This change in signal is analyzed by the electronics and converted into a digital PPM (parts per million) level. The PPM level is compared to the trip points for that zone. If the PPM exceeds the Low Trip point, the Low Alarm Relay will be energized. If the signal continues to increase, the Main Alarm will be energized and ultimately the High Alarm. Once the system enters Low, Main or High Alarm for any zone, it will remain in that mode until the problem is cleared and the system is Reset.

Sensitivity

The system is sensitive in varying amounts, to all of the halogen based gases, those that contain molecules of

either fluorine, chlorine or both. As part of the setup, the specific gas to be monitored by each zone is entered into the system. The computer control compensates for the differing sensitivities, resulting in a true PPM reading for the agent in the zone being tested.

The SSG system maintains accuracy through its automatic rezeroing capability. Periodically, the system switches to the Fresh Air inlet, and reestablishes its baseline level.

There is no direct relationship between the amount of refrigerant or agent leaking and the concentration level being measured. The size of the room, the location of the pick up point relative to the leak point, and the air pattern, all will affect the actual concentration at the inlet. However, by judicious location of the inlets (see installation section) and maintaining the trip point at a level not too far above the ambient, leaks should be detected substantially before they otherwise would be noticed. See Appendix B for a detailed discussion of room volume considerations.

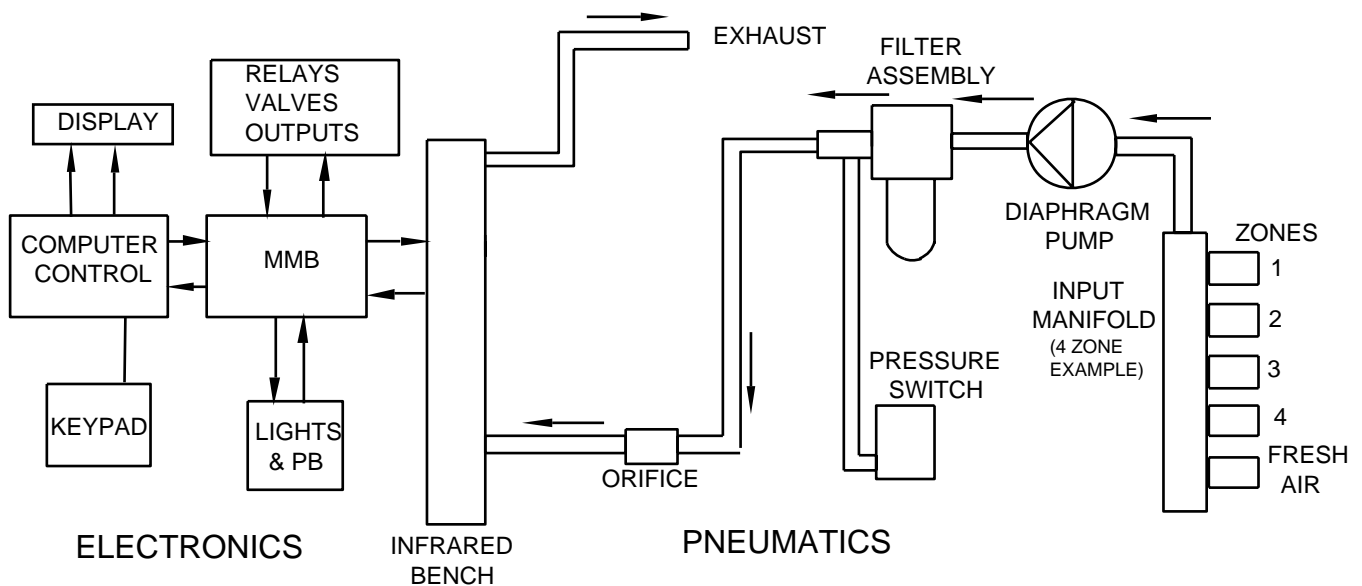

Fig. 1
System Block Diagram

INSTALLATION

Material Required

Packed with the system:

1. This manual.
2. The coarse tube end filters.
3. The CTS/Warranty card which is to be completed and returned after start-up.

User supplied or optionally purchased.

1. Plastic tubing 1/4" OD for the remote pickup points and fresh air inlet.
2. Horns, lights or other warning devices.
3. Wire for primary power and alarm devices.

(Refer to the Series SSG Installation Layout on page 6 for an overview of installation requirements.)

Location

Since the monitor measures the concentration of refrigerant or agent in air, each zone pick up point should be mounted where it is most likely to sense leaking gas. The criteria to consider in selecting a location include:

1. As close to the area of potential leaks as possible. On the "downstream" side of the air flow pattern in the room.
2. Since halogen based gases are typically heavier than air, the pick up tubes should be terminated 20" (50 cm.) above the floor.
3. The control unit should be located such that the farthest pick up point will require no more than 250 feet (75 meters) of tubing. The Fresh Air inlet tubing can be longer if required.
4. The Monitor includes electronics and an infrared bench, the mounting point should be free from vibration to the extent practical.

⚠ CAUTION

MOISTURE CAN DAMAGE THE INFRARED BENCH. PICK UP POINTS AND THE FRESH AIR INLET MUST BE LOCATED AND PROTECTED WHERE NECESSARY TO PREVENT WATER FROM ENTERING THE SYSTEM.

Mounting and Tubing Installation

Drill the necessary holes and mount the unit.

Zone Pick Up Tubes

Install the 1/4" tubing from each zone pick up point to the zone inlet fittings on the right side of the control unit. It is recommended that you start with zone 1 at the top, and continue in sequence until the tube for each zone is

installed. Terminate the tubing with the coarse filters.

Fresh Air Pick Up Tube

Since the fresh air input is the means by which the system maintains it's accuracy, **it must be located at a point that cannot be reached by any leaking gas.** Install the tube for fresh air from the Fresh Air inlet at the bottom of the input manifold to a point outside the area being monitored. Terminate the tube with its coarse filter.

Suggested locations are:

An adjacent room, hallway, or office

Up into an air inlet duct

Outside the building

(As long as you are very careful to protect it from rain or rain splash. Water will damage the infrared bench.)

Primary Power Wiring

All installation wiring, service and maintenance should be done by a qualified electrician in accordance with national and local codes. Refer to the primary power wiring diagram (Fig. 2). Primary power should be supplied to the unit through the opening located on the left side of the box. It is strongly recommended that power be supplied from a 2 pole circuit breaker, located in reasonable proximity to the system. NOT by plugging into a wall socket. The unit is a continuous monitor. If a wall socket is used, there is a risk that the unit will inadvertently be unplugged putting it off line.

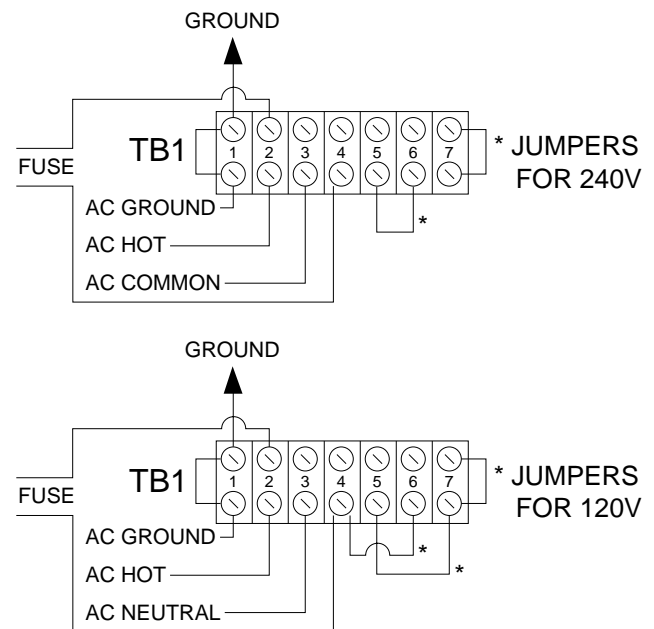

NOTE: UNITS FOR USE IN JAPAN ARE 100V/200V.

Fig. 2
Primary Power Wiring Diagram

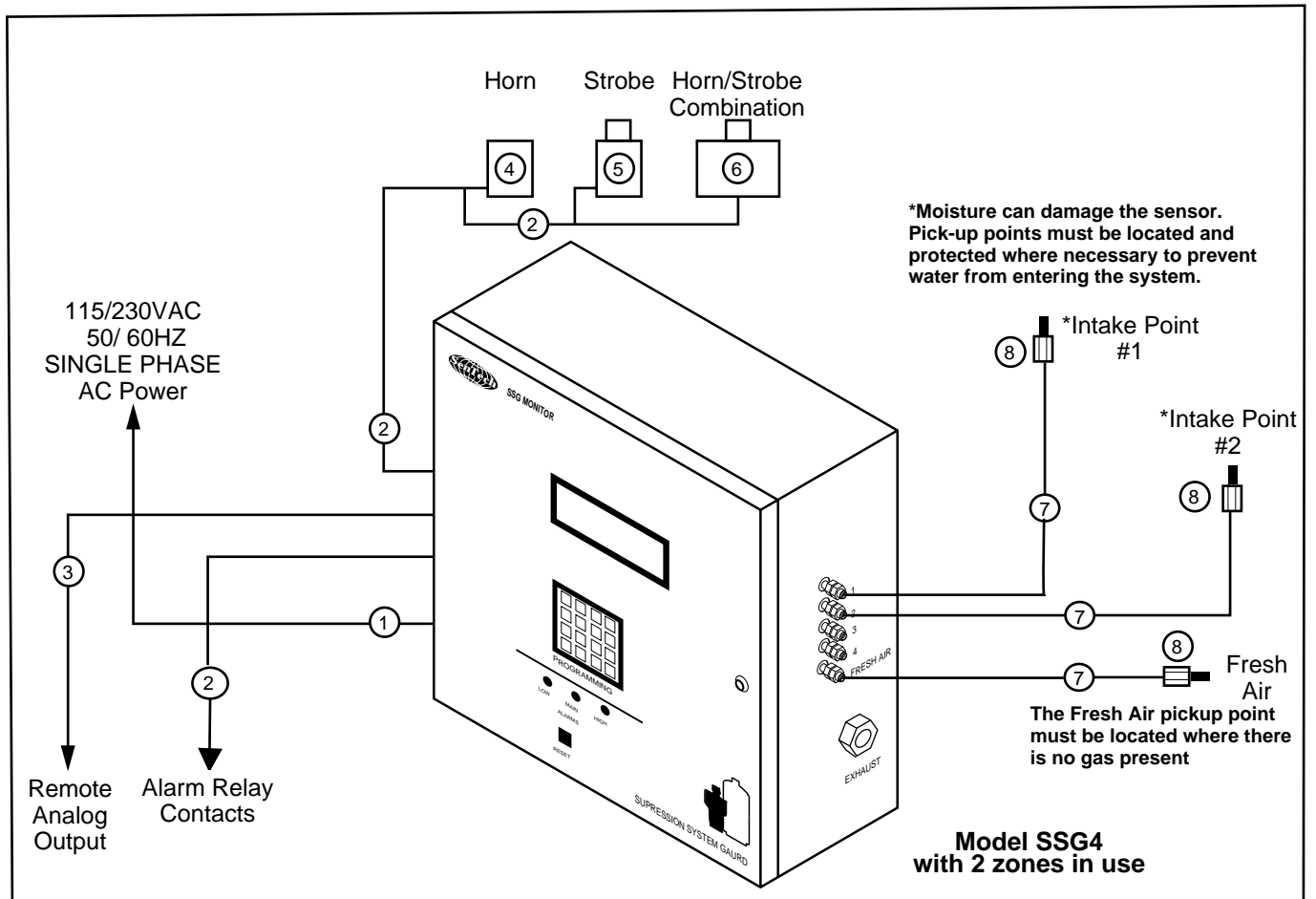

*Moisture can damage the sensor.
Pick-up points must be located and
protected where necessary to prevent
water from entering the system.

*Intake Point
#1

*Intake Point
#2

Fresh Air
The Fresh Air pickup point
must be located where there
is no gas present

Item	Description	Required	Supplied with Unit	Supplied by Customer	Optional	Available from SenTech	Comments
1	16 Gauge, 3 Conductor Cable	yes	no	yes		no	
2	18 or 22 Gauge, 2 Conductor Cable	no			yes	no	Required for horn, strobe or combination
3	2 Conductor Twisted Pair Shielded Cable	no			yes	no	Required for remote analog output
4	Horn	no			yes	yes	
5	Strobe Light	no			yes	yes	
6	Combination Horn and Strobe	no			yes	yes	
7	1/4" OD X 1/8" ID Plastic Tubing (recommend flame retardant, smoke resistant)	yes	no			yes	Available in 250 foot reels
8	Coarse Filter	yes	yes				For mounting at the end of the tubing

SERIES SSG INSTALLATION LAYOUT

OPTIONAL CONNECTIONS

Alarm Relay Contacts

Warning lights, horns or other devices are actuated using the Alarm relay contacts on TB2 as shown (Fig. 3). Use an auxiliary contactor for heavy loads such as exhaust fans. **Note: alarm contacts are rated (5) amps/240 VAC maximum.** (Refer to the system wiring diagram for a schematic of the alarm relays.)

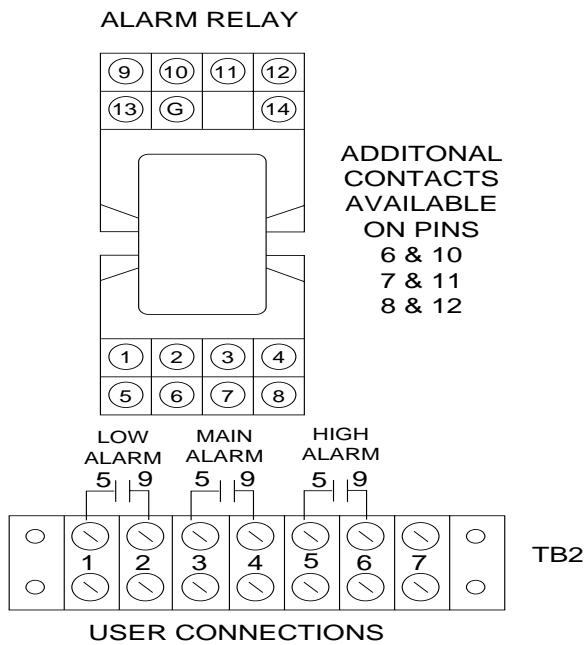

Fig. 3
Alarm Relay Option Wiring

Analog Outputs

For the following discussion refer to Fig. 4 Analog Outputs.

0-10 Volt DC Analog Output

The 0-10 Volt DC analog output is available at TB-3 (FIG. 4). Terminal 1 is the positive side of the output and terminal 3 is the common or negative side of the output.

4-20ma Output (Optional)

If the 4-20ma option has been purchased, the output is available at terminals 2 and 3 of TB3. Terminal 2 is the plus current output and terminal 3 is the common.

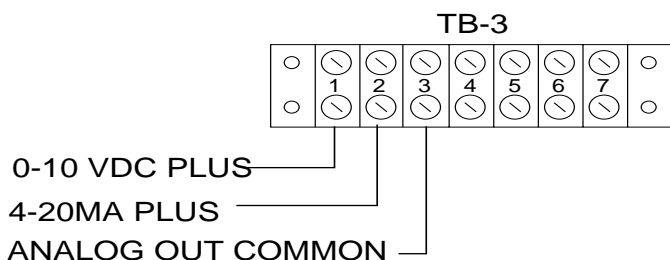

Fig. 4
Analog Out

STARTUP

BEFORE PROCEEDING DOUBLE CHECK YOUR WIRING

Apply power to the monitor. The unit will now go through its normal startup checks and warmup procedure.

(If during startup a fault condition is detected, follow the instructions on the screen, and refer to the trouble shooting section of this manual.)

At the completion of warmup, the unit will be in Automatic Mode monitoring the first zone. The monitor will now be operating under the default settings it had when it left the factory. These may or may not be optimal for this installation.

SETUP

The Setup procedures will allow you to select the following parameters for each zone:

- 1. Zone on or off:** For multizone systems, you should turn off zones that are not in use to avoid wasting time in those zones.
- 2. Refrigerant/Agent:** The setup screens will provide gas codes for the various refrigerants and fire suppression agents.
- 3. Tube Length:** You can optimize the amount of time spent in each zone by entering the approximate length of tubing used for that zone. For single zone units, it is recommended that the tube length be set for 100 feet.
- 4. Low Alarm Level:** This will set the PPM level for a Low Alarm condition for that zone.
- 5. Main Alarm Level:** This sets the trip point for Main Alarm.
- 6. High Alarm Level:** This sets the trip point for High Alarm. It is recommended that this trip point be set at or near full scale.

Before proceeding with the Setup, it is a good idea to review and make notes on your intended settings for each zone. A rough "ball park" approximation is more than adequate for tube length.

The display will provide step by step instructions for the Setup procedure. (For a detailed description of the procedures, turn to the section on Programming and Operator Interface.)

Enter "#" to exit Automatic.
Enter "4" for Setup
Enter "999" and then "#" to access the entry screen
Enter "4" for setup

Follow the instructions for determining gas codes, selecting the zones you want active, and setting up each zone.

After you have completed setting up all the zones you will use, and turning off the unused zones, exit back to the Automatic Mode, for the final system checks.

FINAL CHECKS

At this point, the system should have all the zones Setup, and it should be monitoring the first zone in Automatic Mode.

All desired zones selected and OK.

Watch the unit as it sequences through all the selected zones. Make certain that all the desired zones are on and the unused zones are off.

Make a note of the PPM readings in each zone. The reading should be less than 5 PPM. If in any zone the unit is reading 10 PPM or higher, or if it has gone into Alarm Mode, it is likely there is a leak present. A high reading may also result from the recent use of a chlorinated cleaning agent. Many industrial degreasers use chlorine based compounds. Examples are trichloroethylene or perchloroethylene. If you are convinced that there is no leak and that there are no other sources of halogen vapors in the room, contact SenTech.

Response to a leak

After checking all zones, the final step is to check for a proper response to the presence of a leak. This will be done by preparing a sample of refrigerant or agent for testing, and then presenting it to the system to make certain it goes into alarm. It is suggested you read through all the steps before starting.

Step 1: Select a zone and remove the inlet tubing from that zone.

Step 2: Preparing a sample.

Obtain a small plastic garbage bag (waste basket size is fine). Open the bag and "fluff" it so that it is full of air.

a) Gaseous Refrigerants or Agents: Insert a fill hose into the bag opening. Close the mouth of the bag around the hose. Crack the valve for a second or less so that a small squirt of refrigerant enters the bag. Keep in mind that the monitor reads in parts per million and a tiny amount of gas will make a relatively high concentration sample. Pull out the hose, and hold the bag tightly closed.

b) Liquid refrigerants: Open the bag slightly and put in a few drops of liquid refrigerant. Close the bag and hold it tightly. Allow time for the refrigerant to gasify. The bag will expand some as the liquid evaporates

Step 3: We will now test to see that unit is functioning by detecting the gas and entering the alarm modes. We are going to use the sample to simulate a concentration of refrigerant or agent in the air that is reasonably higher than the trip point.

NOTE: THE MORE THE READING EXCEEDS THE TRIP POINT THE SHORTER THE TIME TO ENTER ALARM.

Holding the bag tightly closed, bring the bag to just under the inlet. Wait until the unit cycles to the chosen zone and then carefully loosen your grip on the bag to allow some gas to escape. Watch the PPM reading. You should allow enough gas to escape to cause the reading to rise well above the Main Trip Point for that zone. Precision is not possible. The goal is to make sure the unit detects the gas and enters Alarm.

There will be a few seconds delay before the PPM reading starts to react.

Step 4: The system should now be in Alarm. Confirm that the Alarm Light is on, and the screen is displaying the Level of alarm that was reached. Check that any optional horns lights or other warning devices are appropriately energized.

Step 5: Remove the gas sample bag from the inlet and wait until the PPM reading drops back to normal. Push the Reset button. The System should clear the Alarms and be back in normal Automatic operation.

Step 6: Reconnect the zone inlet tube.

Step 7: Initial and date the inspection sticker on the inside front cover of the unit.

Step 8: Dispose of the gas sample in an appropriate manner.

Step 9: Fill out the CTS/Warranty form completely and return it to SenTech in the envelope provided. This is an important step to establish warranty. Please use this opportunity to make any suggestions for improvements.

Step 10: If you are part of the user organization, store this manual in a safe place. If you are an installing contractor, please turn over the manual to the user. If you need any additional manuals, call SenTech and we will be pleased to provide them at no charge (make a note of the unit serial number when requesting a manual).

Basic installation and startup is now complete. The unit should be on line and monitoring.

The remainder of this manual includes further information on operational characteristics, programming, preventive maintenance, trouble shooting, parts lists, and a detailed wiring diagram.

SYSTEM OPERATION

The normal state of the SSG system will be Automatic mode, cycling through the zones, sampling the air, and sensing for leaks. The state of the system, the zone it is in, and the PPM level will be displayed on the backlit LCD display. Refer to Figure 5.

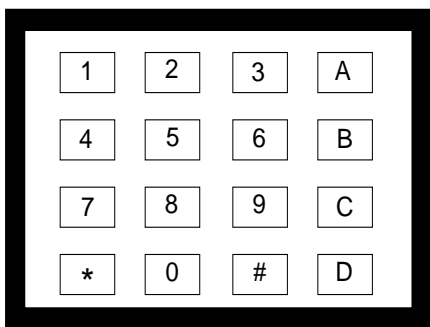

PROGRAMMING



ALARMS



RESET

Fig. 5
Front panel

After applying power (or after a temporary power outage) the system will revert to the Start Up Mode. If the system has been switched to some other mode such as Manual, after some time delay it will revert to Automatic. The only exception is Fault Mode. Once a Fault is detected, it will remain in Fault until the problem is corrected and there is a manual reset.

START UP MODE

When the system first enters Start Up mode, it will go through several steps before entering fully automatic operation. For a detailed description of all the screens and operator interface options, turn to Appendix A "Programming and Operator Interface"

ID Screen

The first screen will be an identification screen, which will last for a few seconds.

Optics Warmup

The second screen will display that the monitor is waiting for the infrared bench to warm up. When the warm up is complete, the system will switch to:

Automatic Rezeroing

During this step, the monitor will be drawing its sample from the Fresh Air input port. During Automatic Rezeroing the screen will count down the time remaining. The system electronics will use the sample time to establish the zero signal, or baseline level. When the monitor is sampling the active zones, it compares the zone signal to the zero signal to determine the concentration of refrigerant.

Periodically, during the course of normal operation, the monitor will automatically rezero itself to maintain its accuracy. When it completes the automatic rezero step, the system will switch to:

Auto Sampling

At this point, the monitor will be sampling the selected zones, checking for leaks.

During Auto Sampling, the system will display: the zone being monitored and the gas concentration level in parts per million. When the system enters Auto Sampling, it starts with the first selected zone. When it completes sampling the first zone, it will Rezero and then switch to the next selected zone. After it completes sampling all the selected zones, it will switch back to the first selected zone and repeat the process. The amount of time spent in each zone will be a function of the tube length entered for that zone. For a single zone unit, the monitor will continuously sample the one zone (except for periodic rezeroing).

ALARM STATUS SCREEN

WHEN THE SYSTEM DETECTS AN ALARM IN ANY ZONE, IT STORES THAT INFORMATION IN AN ALARM STATUS SCREEN. TO DETERMINE WHICH ZONES ARE IN ALARM AND THE LEVEL OF ALARM:

Enter "#"

Enter "1" for Zone Alarms

Step through the screens to determine the Zones in alarm and the level of Alarms for each zone.

Low Alarm

If the PPM level for the monitored zone exceeds the Low Alarm trip point, the monitor will enter Low Alarm Mode. The Low Alarm relay will be energized, the Alarm LED will be energized, and the system will store a Low Alarm for that zone. Once the Low Alarm relay is energized for any zone, it will remain energized until there is a Manual Reset (this holds for any of the alarm states).

Once the system enters Low Alarm, it will extend the period of time for that zone, to determine if the concentration will increase to the next level of alarm. If during this additional time the PPM level remains below the next trip point, the system will switch to the next zone. Otherwise:

Main Alarm

If the Main Alarm trip point is reached or exceeded, the system first goes through a leak wait period. This is to confirm that an actual Main Alarm has occurred, rather than a short term transient event. The length of the wait period depends upon the difference between the concentration level and the Main Alarm trip point. The larger the signal, the shorter the wait time.

If the concentration level falls below the Main Alarm trip point for a few seconds, the system will assume it was a transient, and switch to the next zone.

If the signal remains above the trip point during the wait period, the system will enter Main Alarm Mode, and the Main Alarm relay will be energized, and remain energized until a Manual Reset. The system will store the alarm status as Main. Once the Main Alarm is determined, the system will add an additional period of time for the zone. This is to determine if the concentration level will continue to rise to the High Alarm trip point. If during this extension, the PPM level remains below the next trip point, the system will switch to the next zone. Otherwise:

High Alarm

Once the High Alarm trip point is reached, the system enters High Alarm Mode. The High Alarm relay is energized and remains energized until a Manual Reset. The System will store the alarm status as High. The system will then switch to the next selected zone and proceed with the Auto Sampling process.

FAULT MODE

If at any time the system detects a Fault condition, it will enter Fault Mode. The Main Alarm relay will energize. The display will indicate the type of Fault detected. All monitoring will stop and the system will remain in Fault Mode until there is a Manual Reset.

Refer to the "Trouble Shooting" section of the manual for a detailed description of the types of faults and the recommended action.

MANUAL MODE

Manual Mode is normally used only for troubleshooting and checkout, or when checking for a leak after an alarm condition has been detected.

Manual is accessed by exiting from Automatic Mode and following the screen instructions. Manual Mode forces the monitor to stay in the selected zone. In Manual, the screen will display the selected zone and the PPM level.

When stepping through the zones, allow 5 or 10 seconds for the PPM level to adjust to that of the new zone. If conditions are changed at the end of a long tube run, allow several minutes for a new air sample to reach the sensor, and the PPM level to stabilize.

When you have completed the desired checks in Manual Mode, exit to Automatic Mode to put the system back into normal operation.

Note: as a safety precaution, the system will automatically revert to Automatic Mode, after a period of time in which there have been no key strokes.

PREVENTIVE MAINTENANCE

Filter Cleaning or Replacement

The only periodic preventive maintenance required is to check and clean or replace the various filters in the unit. There are three types of filters to check.

Cooling Air Inlet Filter located on the left side of the enclosure should be cleaned or replaced if it becomes laden with dust. It can be cleaned by washing in warm water and allowed to dry.

5 Micron Filter located in the plastic bulb at the upper right inside the monitor, should be replaced when it has turned a very dark gray from accumulated dust. After replacing the filter, be sure to tighten the plastic bulb to an air tight seal.

Quarterly Performance Check: Once per quarter, go through steps 1 through 7 of the Final Checks procedure.

APPENDIX A PROGRAMMING AND OPERATOR INTERFACE

START UP SCREENS

When power is applied to the system, it will step through a series of start up screens.

ID Screen

```
Sentech SSG
SenTech Corp
888-248-1988
```

Optics Warm-Up

```
Optics Warm-up
Please Wait
*****
```

The asterisks represent a series of numbers that will be displayed. These numbers are the voltage output from the amplifier board to the control board. They are useful during initial factory setup and occasionally will be helpful in troubleshooting. The Optics Warm-up phase should last approximately nine minutes.

Copyright

```
Sentech SSG
Copyright 1996
```

Autozero

```
Autozero
**
Please Wait
```

The asterisks represent a countdown in seconds to the completion of Autozero.

Autozero is the last screen of the start-up phase. This same screen will appear each time the unit does its periodic autozeroing.

Auto Sampling

```
Auto Sample AREA **
PPM *** HH:MM

Press # for Menu
```

The asterisks by area will be the number of the current area. The asterisks by PPM will be the PPM level being detected for the current zone. The HH:MM is the current time in hours and minutes. Auto sampling is the normal mode. The system will remain in auto sampling except for the periodic auto zeroing.

To access the other menus press #

FIRST MENU SET

Pressing the # key in Auto Sampling, will bring up the first Menu screen.

First Menu Screen

```
1)...AREA Alarms
2)...Rezero
3)...Manual
4)...Setup # Exit
```

Pressing any of the 4 numbers will take you to that function. Pressing # will take you back to Auto Sampling.

1. Alarm Status

```
Alarm Status

*-Next PT #Exit
```

As you press the asterisk key unit will step through the zones that are in alarm and tell you the level of alarm. Once it has displayed all the zones in alarm, It will display

```
No More Alarms
```

You can now return to the main Auto Sampling screen.

2. Rezero

Pressing 2 will take you to the Auto Zero function just as in start up. At the end of Auto Zero, the system will return to Auto Sampling.

3. Manual

Pressing 3 will take you to the first manual screen.

```
Manual Override
Area 1 _
Enter Area Number
Followed by ##
```

(Note in this Manual and in the screens "Zone" and "Area" are used interchangeably).

If Zone 1 is the one you want simply enter#. Otherwise, enter the zone number followed by # and then another#. This will put the system in Manual

```
Manual Override
Area 1
PPM 0
Press # to exit
```

The Area 1 and 0 PPM are just examples the data displayed. Exit from Manual Override to Auto Sampling when you are finished running your tests.

4. Setup

Pressing 4 will take you to the second set of menu screens.

SECOND MENU SET

Password screen

SenTech Monitor
ENTER PASSWORD
Followed by #
Code: 0_

To get beyond this screen it will be necessary to enter an access code followed by #. Normally the system will ship with 4 access codes. These are: '111', '222', '333', and '999'. As will be discussed below, the first three access codes can be changed. '999' is locked into the system and may not be modified. Access code '999' is listed on a decal on the inside of the front cover of the unit.

If it is desired to limit access to the following screens. It is recommended that the access code on the decal be blacked out and the codes changed. However, it is strongly recommended that a record be kept somewhere of the new codes.

After entering the code and # one of the following 2 screens will appear briefly.

Access Code Accepted

Access is Approved

Make Selection

Access Code Not Accepted

SenTech Monitor
ENTER PASSWORD
Followed by #
Access Denied

If the access code is not accepted, you will have to go through the all the steps again.

If the access code is accepted the next menu screen will appear.

1- AREA Alarms
2- Rezero 3- Manual
4- Setup 5- Cal
C- Code #- Exit

1- Zone Alarms This is identical to the zone alarms

command on the first menu screen. It will allow you to determine which zones are in alarm and their level of alarm.

2. Rezero This is identical to the rezero command on the first menu screen, and will put the system through an Autozero.

3- Manual As with the first two commands, this is identical to the Manual command on the first menu screen.

4. Setup This command will allow you to enter the Setup portion of the program.

First Setup Screen

Determine Gas Codes
For Each AREA
1- Gas Codes 2- Setup
3- Zones #- Exit

Gas Codes Screen

Gas Code Selections
1-R11 2-R12 3-R13
4-R22 5-R1136-R114
A-bort #-Next

There are as of this writing a total of 3 Gas Code screens. More will be added with time. If one of the refrigerants you are detecting is not listed, Call SenTech 1-888-248-1988. Our Tech support will recommend the closest code to use.

Setup Screens

There are two setup screens for each zone.

AREA 1_
Gas 5_
Distance 100_
A-bort B-ack #-Next

Alarm Low 30
Alarm Main 100
Alarm High 500
A-bort B-ack #-Next

Continuation Screen

Press # to Exit
or * for Next Area

After you have entered the data for each zone, press # to exit.

When the unit is shipped every zone will be setup with nominal values.

3. Zones

If you are going to use less than the full complement of zones, it will save time to shut off the unused zones. For ease of understanding, it is recommended that you use the zones starting with zone 1 and continue in sequence. For example if you only need three zones of a four zone unit, use zones 1, 2, and 3 and shut off zone 4. Later if you add a pickup point, you can turn zone 4 back on. To shut off unused zones, go to the first set up screen and select 3. Zones.

**AREA Selection
to continue**

**AREA 1_
Status 1
1- Enable 0- Bypass
A- Return to Menu**

Note: Use the # key to enter your data

This completes the setup procedures.

5. Cal

As of the date of this manual, the CAL function is not implemented.

If you desire procedures for recalibrating your unit. Call SenTech @ 888-248-1988 or 317-248-1988

C- Code

This screen will allow you to change access codes. There are 4 possible access codes.

- Code 1- 111
- Code 2- 222
- Code 3- 333
- Code 4- 999

Codes 1, 2, and 3 can be changed. Code 4 is locked at 999.

**Select Code # to
View or Change Code

Access Code # 1_**

Enter the code you want to check or change and press #

**Access Code # 1
Code 111_

Exit**

Change the codes if you desire. Each code can have up to 3 numbers.

There is 1 other hidden menu that can be reached from the second set of menu screens. This menu will allow you to change the time and date, and to permanently change the number of zones.

Hidden Menu

From the menu reached after entering the access code, enter **B**. This will bring up the calendar menu.

**RTC Month 1_
RTC Day 1
RTC Hour 1
RTC Min 1**

Enter the current month, day, hour (24 hour clock) and minute. Use the # key to complete your entries.

After the final # key, the following menu will appear.

**Press C for
Gas Calibration
Press # to Exit
* Number of AREA**

As noted above, gas calibration is not implemented. Number of zones, establishes the total number of zones available on the unit. This has been set at the factory, and should not be reset.

Appendix B: SenTech Room Volume Considerations (English)

Normal industry practice is to think about refrigerant leaks in terms of pounds of refrigerant per unit time such as lbs/hr or ozs/yr. This is a natural and logical way of looking at it. The system monitors the amount of refrigerant present in the air in Parts Per Million (ppm) by volume of refrigerant molecules as compared to air molecules. In order to develop a relationship between the leak rate in weight per unit time and ppm reading of the monitor, there are a number of items that need to be considered and accounted for. These are:

1. Room Volume.
2. The relationship between refrigerant amount in weight compared to refrigerant volume at the temperature and pressure of the room.
3. The amount of time the refrigerant has been leaking.
4. The rate at which fresh air enters the room (stale air is exhausted).
5. The location of the monitor inlet relative to the leak, the air patterns of the room, and the rate at which the leaking refrigerant expands to fill the room.

For a given specific situation items 1 through 4 are either known, can be calculated, or can be estimated. Item 5 is virtually unknowable, therefore in all the formulas and sample calculations it is assumed that leaking refrigerant expands immediately to fill the room. This is a reasonable and conservative assumption on the basis that you have located the monitor following the recommendations outlined in the installation section. If you have followed those recommendations, the monitor should see a higher concentration sooner than the idealized formulas.

The equations have been developed for two cases. **Case I** is for a sealed room, no air turnover. **Case II** is for a room with a known turnover of air.

To be able to convert between a leak rate in cubic feet per hour to a leak rate in pounds per hour the molecular weight of the refrigerant needs to be known. If you know the molecular weight of the refrigerant, you can calculate the necessary conversion factors at normal atmospheric pressure and room temperature.

$$\frac{\text{Mol Wt(gms)}}{1(\text{mole})} \times \frac{1(\text{mole})}{22.4(\text{ltrs})} \times \frac{1(\text{pound})}{454(\text{gms})} \times \frac{28.32(\text{ltrs})}{1(\text{cuft})} \times \frac{273}{293} = \frac{\#}{\text{cuft}}$$

Substituting for R-22 which is 86.48 grams/mole, you get $0.22 \frac{\#}{\text{cuft}}$.

Conversion Factors for Common Refrigerants

R-22	.22 #/cuft	4.46 cuft/#
R-12	.31 #/cuft	3.18 cuft/#
R-11	.36 #/cuft	2.80 cuft/#
R-502	.29 #/cuft	3.45 cuft/#
R-123	.41 #/cuft	2.41 cuft/#

PPM READINGS AND LEAK RATE RELATIONSHIP DEFINITIONS:

- PPM = Monitor PPM reading or trip point PPM setting
- LR = Leak Rate of refrigerant in cubic feet per hour
- FA = Fresh Air into the room in cubic feet per hour
- VOL = Volume of the room in cubic feet
- t = Time in hours (There are 8760 hours in one year)
- R = Amount of refrigerant in the room in cubic feet
- LR_{min} = Minimum leak rate that will reach a given PPM

Case I: Sealed Room

$$\text{PPM} = \frac{\text{LR} \times t \times 10^6}{\text{VOL}} \quad t = \frac{\text{PPM} \times \text{VOL} \times 10^{-6}}{\text{LR}}$$

$$R = \text{PPM} \times \text{VOL} \times 10^{-6}$$

Case II: Room with Air Changing

$$\text{PPM} = \frac{\text{LR}}{\text{FA}} \left(1 - e^{-\frac{\text{FA}}{\text{VOL}}t}\right) 10^6$$

$$t = \frac{\text{VOL}}{\text{FA}} \times \ln \left(\frac{\text{LR}}{\text{LR} - \text{PPM} \times \text{FA} \times 10^{-6}}\right)$$

$$\text{LR}_{\text{min}} = \text{PPM} \times \text{FA} \times 10^{-6}$$

Sample Calculations (Assuming The room is 40 feet by 30 BY 10 feet = 12,000 cuft)

Case I: Sealed Room

1. How much refrigerant is necessary to cause a 25 ppm reading ?

$$R = 25 \times 12000 \times 10^{-6} = .3 \text{ cuft}$$

If it is R-22: .3 cuft x .22 lb/cuft = .066 lbs

2. If the leak rate is 300 lbs./year of R-22, how long will it take to reach 25 ppm ?

$$\frac{300 \text{ lbs}}{\text{yr}} \times \frac{1 \text{ yr}}{8760 \text{ hr}} \times \frac{4.46 \text{ cuft}}{\text{lbs}} = .153 \text{ cuft/hr}$$

$$t = \frac{25 \times 12000 \times 10^{-6}}{.153} = 1.96 \text{ hrs}$$

Case II: Room with Air Changing

Assume the same room 12,000 cuft.

Assume fresh air at 100 cfm or 6000 cuft/hr (1 air changes in 2 hour).

1. What is the minimum leak that will reach 25 ppm ?

$$\text{LR}_{\text{min}} = 25 \times 6000 \times 10^{-6} = .15 \text{ cuft/hr}$$

for R-22: .15 cuft/hr x .22 lb./cuft = .033 lbs/hr or 289 lbs/yr

2. How long will it take to detect a leak of 500 lbs/yr of R-22?

$$500 \text{ lbs/yr} = .26 \text{ cuft/hr}$$

$$t = \frac{12000}{6000} \times \ln \left(\frac{.26}{.26 - 25 \times 6000 \times 10^{-6}}\right) = 1.72 \text{ hrs}$$

3. If the trip point is set at 10 ppm, what is the minimum leak rate of R-123 that will trigger the alarm ?

$$\text{LR}_{\text{min}} = 10 \times 6000 \times 10^{-6} = .06 \text{ cuft/hr}$$

for R-123: .06 x .41 lbs/ft = .0246 lbs/hr or 215 lbs/yr

4. How long will it take to detect a leak of 300 lbs/yr of R-123 ?

$$300 \text{ lbs/yr of R-123} = .0825 \text{ cuft/hr}$$

$$t = \frac{12000}{6000} \times \ln \left(\frac{.0825}{.0825 - 10 \times 6000 \times 10^{-6}}\right) = 2.6 \text{ hrs}$$

These numbers represent worst case conditions. With the monitor placed close to the potential leak points and on the "downwind" side of the air flow, the trip points are likely to be activated sooner.

Appendix B: SenTech Room Volume Considerations (Metric)

Normal industry practice is to think about refrigerant leaks in terms of weight of refrigerant per unit time such as kg/hr or kg/yr. This is a natural and logical way of looking at it. The system monitors the amount of refrigerant present in the air in Parts Per Million (ppm) by volume of refrigerant per volume of air. In order to develop a relationship between the leak rate in weight per unit time and ppm reading of the monitor, there are a number of items that need to be considered and accounted for. These are:

1. Molecular weight of the refrigerant.
2. Density of the refrigerant at the temperature of the room.
3. Room volume.
4. The rate at which fresh air enters the room.
5. The location of the monitor inlet relative to the leak, the air patterns of the room, and the rate at which the leaking refrigerant expands to fill the room.

For a given specific situation items 1 through 4 are either known, or can be calculated. Item 5 is virtually unknowable, therefore in all the formulas and sample calculations it is assumed that leaking refrigerant expands immediately to fill the room. This is a reasonable and conservative assumption on the basis that you have located the monitor following the recommendations outlined in the installation section. If you have followed those recommendations, the monitor should see a higher concentration sooner than the idealized formulas.

The equations have been developed for two cases. **Case I** is for a sealed room, no air turnover. **Case II** is for a room with a known turnover of air.

To be able to convert between a leak rate in cubic meters per hour to a leak rate in kilograms per hour the density of the refrigerant must be known. At normal atmospheric pressure and room temperature.

$$\text{DENSITY (kg/m}^3\text{)} = \frac{\text{Mol Wt(gms)}}{22.4(\text{ltrs})} \times \frac{273}{293} \times \frac{1(\text{kg})}{1000(\text{gms})} \times \frac{1000(\text{ltrs})}{1(\text{m}^3)}$$

As an example for R-22, Mol Wt = 86.48 gm/mole.
Therefore density = 3.59 kg/m³, or 0.28 m³/kg

Conversion Factors for Common Refrigerants

R-22	3.59 kg/m ³	0.28 m ³ /kg
R-12	4.96 kg/m ³	0.20 m ³ /kg
R-11	5.76 kg/m ³	0.17 m ³ /kg
R-502	4.64 kg/m ³	0.21 m ³ /kg
R-123	6.56 kg/m ³	0.15 m ³ /kg

PPM READINGS AND LEAK RATE RELATIONSHIP DEFINITIONS:

- PPM = Monitor PPM reading or trip point PPM setting
- LR = Leak Rate of refrigerant in cubic meter per hour
- FA = Fresh Air into the room in cubic meter per hour
- VOL = Volume of the room in cubic meter
- t = Time in hours (There are 8760 hours in one year)
- R = Amount of refrigerant in the room in cubic meters
- LR_{min} = Minimum leak rate that will reach a given PPM

Case I: Sealed Room

$$\text{PPM} = \frac{\text{LR} \times t \times 10^6}{\text{VOL}} \quad t = \frac{\text{PPM} \times \text{VOL} \times 10^{-6}}{\text{LR}}$$

$$R = \text{PPM} \times \text{VOL} \times 10^{-6}$$

Case II: Room with Air Changing

$$\text{PPM} = \frac{\text{LR}}{\text{FA}} (1 - e^{-\frac{\text{FA}}{\text{VOL} \cdot t}}) 10^6$$

$$t = \frac{\text{VOL}}{\text{FA}} \times \ln \left(\frac{\text{LR}}{\text{LR} - \text{PPM} \times \text{FA} \times 10^{-6}} \right)$$

$$\text{LR}_{\min} = \text{PPM} \times \text{FA} \times 10^{-6}$$

SAMPLE CALCULATIONS (ASSUMING THE ROOM IS 15 METERS BY 10 METERS BY 3 METERS = 450 CUBIC METERS)

Case I: Sealed Room

1. How much refrigerant is necessary to cause a 25 ppm reading ?
R = 25 x 450 x 10 = .0011 cubic meter
If it is R-22:
Amount of refrigerant = .0011 m³ x 3.59 kg/m³ = .004 kg
2. If the leak rate is 150 kg/year of R-22, how long will it take to reach 25 ppm ?
$$\frac{150 \text{ kg}}{\text{yr}} \times \frac{1 \text{ yr}}{8760 \text{ hr}} \times \frac{.28 \text{ m}^3}{\text{kg}} = 0.0048 \text{ m}^3/\text{hr}$$

$$t = \frac{25 \times 450 \times 10}{0.0048} = 2.35 \text{ hrs}$$

Case II: Room with Air Changing

- Assume the same room (450 m³).
Assume fresh air at 225 m³/hr (1 air changes in 2 hour).
1. What is the minimum leak that will reach 25 ppm ?
LR_{min} = 25 x 225 x 10 = 0.0056 m³/hr
for R-22:
0.0056 m³/hr x 3.59 kg/m³ = 0.02 kg/hr OR 175 kg/yr
 2. How long will it take to detect a leak of 200 kg/yr of R-22?
200 kg/yr = 0.023 kg/hr
$$t = \frac{450}{225} \times \ln \left(\frac{.023}{.023 - 25 \times 225 \times 10^6} \right) = 4.0 \text{ hrs}$$
 3. If the trip point is set at 10 ppm, what is the minimum leak rate of R-123 that will trigger the alarm ?
LR_{min} = 10 x 225 x 10 = .00225 m³/hr
for R-123: .00225 x 6.56 kg/m³ = .0148 kg/hr OR 130 kg/yr
 4. How long will it take to detect a leak of 150 kg/yr of R-123 ?
150 kg/yr of R-123 = .0026 m³/hr
$$t = \frac{450}{225} \times \ln \left(\frac{.0026}{.0026 - 10 \times 225 \times 10^{-6}} \right) = 4.0 \text{ hrs}$$

These numbers represent worst case conditions. With the monitor placed close to the potential leak points and on the "downwind" side of the air flow, the trip points are likely to be activated sooner.

- 1. LPB Board 420034
- 2. Keypad Display 420035
- 3. MMB Board 420033
- 4. RTU-17 Board 420031
- 5. Fuse 3 Amp Fast 410034
- 6. Relay 24 volt 410087

- 7. Pressure switch 420038
- 8. Transformer T1 410039
- 9. Transformer T2 420036
- 10. Coarse Filter 410044
- 11. Manifold 1 Zone 420040
- Manifold 4 Zone 420041
- Manifold 8 Zone 420042

- 12. Diaphragm pump 410024
- 13. 5 micron element 410162
- 14. Filter Assembly 420043
- 17. IR Bench 420030

Not Illustrated

- Cooling filter 410018
- .010 Orifice 410136

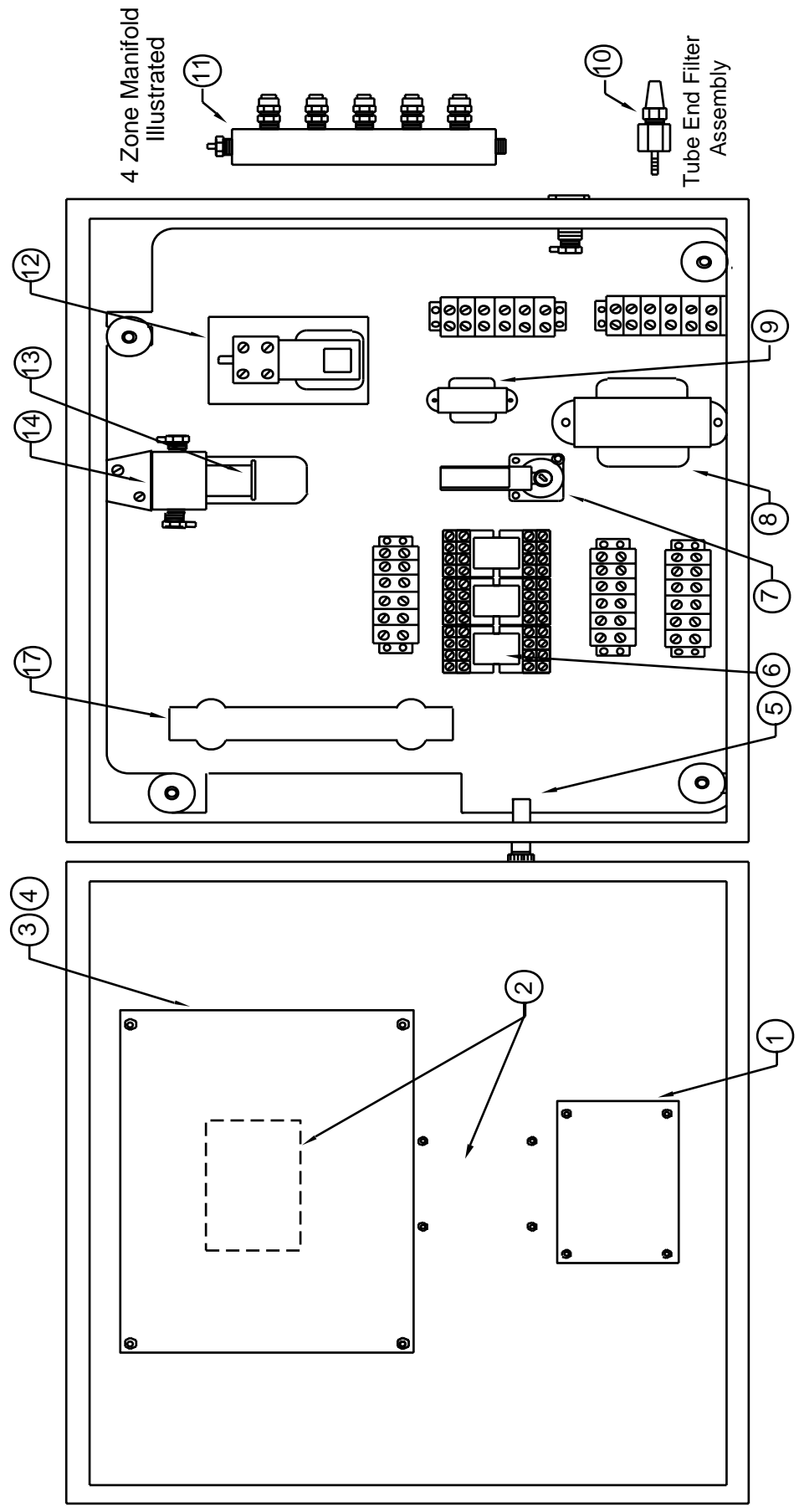

MODELS SSG1, 4, 8

Troubleshooting Guide

Before starting, refamiliarize yourself with the START-UP section of the manual. Depending on the problem, you may need to prepare a sample of refrigerant to use in testing. Certain of these tests will require the use of a volt/ohm multimeter.

Symptom	Remedy
1. No power.	<ol style="list-style-type: none">1. Check the fuse and replace if failed.2. Check incoming AC Power at TB1-2 and TB1-3 120 (240) Volts AC.
2. PNEUMATICS FAILURE.	<ol style="list-style-type: none">1. Check that the diaphragm pump is operating and replace if it has failed.2. Check that the tubing from the diaphragm pump output through the remainder of the circuit is not kinked or has not come loose at any point. Refer to Figure 1.4. Either the orifice or the 5 micron filter or both have become partially or completely blocked or there is a blockage in the tube run for one of the zones.<ol style="list-style-type: none">a). Reset the unit and allow it to cycle through the active zones. If the flow is ok, except in one or more zones, check for blockages in the low flow zone. If the flow is low in all zones, go to b).b). Unscrew the plastic bottle and remove the 5 micron filter. Replace the bottle and recheck the flow. If the flow is ok, replace the 5 micron filter element.c). If the flow remains low, remove the orifice and clean it by blowing compressed air through it. Recheck the flow. If it is not back to normal, replace the orifice. Note, the orifice must be replaced with the arrow pointing towards the optical bench.
4. Failure to detect a leak/ suspected low sensitivity.	<ol style="list-style-type: none">1. Alarm light is on indicating an alarm, but external alarm devices (horns, lights, etc) not actuated.<ol style="list-style-type: none">a). Check for 24 volts DC at the alarm relay coil between p13 and p14. If there is no voltage, check that JP19 is properly seated, and there are no loose wires in the alarm relay circuitry.b). If voltage is present, check that the relay is energized by testing for continuity at an unused set of normally open contacts (see diagram on the inside front cover of the enclosure). If the relay is not energized, replace it.c). If the relay is energized, check the wiring to the external devices, and check the devices themselves for proper operation.2. Alarm light(s) not on. Check the trip point settings of the unit to make certain that they are not set too high. If the trip point is too high, reset it and repeat steps 3 through 6 of the start-up procedure to confirm proper operation.3. If steps 1 through 2 have not uncovered the problem, repeat steps 3 through 6 of the start-up procedure. If the system does not respond properly, there has been a failure in the electronics or sensor.4. If all of the checks indicate the unit is operating properly, yet it still believed that a leak was not detected by the system. Review the Location section of the installation procedure. It may be that the pick up point for that zone is not located in an appropriate position, OR THE FRESH AIR PICKUP MAY BE LOCATED IN AN AREA WHERE REFRIGERANT OR AN AGENT IS PRESENT.

Symptom

Remedy

5. System has gone into alarm and it is believed there is no leak, Flow Failure is NOT indicated.

1. Clear the Alarms and repeat steps 3 through 6 of the start-up procedure. If the unit appears to operate normally, there may have been a transient phenomenon that caused the alarm. Some examples are:
 - a). Someone using a halogen based degreaser such as trichloroethylene near the system.
 - b). A leaky purge that caused a transient increase in the refrigerant level.

Monitor the system closely for the next several weeks to see if it continues to operate normally.

2. If the system goes into alarm yet the reading indicates a very low PPM. Check that the trip point setting has not been changed to 0 PPM or a very low value that is likely to be below ambient conditions. If that is the case, reset the trip point to the appropriate value for your environment, and recheck as in step 1 above.
3. If the system goes into alarm and the reading is above the trip point, there are three likely possibilities:
 - a). There is in fact a leak in the refrigerant system.
 - b). There is a high ambient level of a halogen based hydrocarbon. This may be the result of chemicals stored in the room (such as a leaking refrigerant cylinder).
 - c). The unit has failed.

Disconnect the fresh air tube and allow the unit to Autozero in the same atmosphere as the room. If the unit still goes into alarm, there has likely been a failure in the control board or sensor.

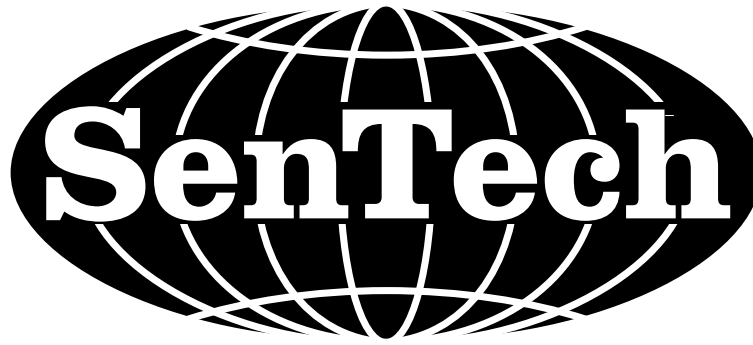

SenTech, gives the following as its complete Limited Warranty Statement:

**SenTech
Manufacturer's Limited Warranty**

SenTech warrants to the original purchaser-user that its equipment, as originally supplied, is free from defects in materials and workmanship and will perform adequately under normal use and service, subject to the following conditions and limits:

If the equipment or any part or parts thereof prove to be defective in normal use, then such item or parts will be repaired or replaced at the option of **SenTech** by **SenTech**, provided that notice of such defect is given by original purchaser-user to **SenTech** within one (1) year from the date of original installation (Warranty Registration Must Be On File) or 15 months from the date of sale of the equipment to the original purchaser whichever comes first.

Warranty is made on condition that such original purchaser-user has returned to **SenTech** the warranty registration form applicable to the equipment, duly and fully completed, within (90) days of the date of purchase by the original purchaser-user.

SenTech's obligation under this warranty is limited exclusively to replacing without charge, or to repairing, at **SenTech's** option, upon return to Indianapolis, Indiana, transportation charges prepaid, any part or parts that shall be found to be defective in material or workmanship during the warranty period. Charges for labor (except for labor performed by **SenTech** factory for repairing defective parts) are not covered and these, plus all other costs and expenses for transportation, insurance, etc., shall be paid for by the Warrantee. If, upon inspection by **SenTech** or its Authorized Service Representative, it is determined that the equipment has not been used in an appropriate manner as described in the **SenTech** Operator's Manual or has been subject to misuse, alteration, accident, damage during transit or delivery, or that such part is from a machine on which the serial number has been altered or removed, then this warranty is void and of no further force or effect. All decisions regarding the existence of defects in material or workmanship or other causes shall be made by **SenTech's** Factory Representative and shall be final and binding upon the parties. Returns shall only be made upon the prior written authorization thereof by **SenTech**.

THE FOREGOING LIMITED WARRANTY IS EXPRESSLY MADE IN LIEU OF ANY AND ALL OTHER WARRANTIES, EXPRESS OR IMPLIED, INCLUDING WITHOUT LIMITATION ANY IMPLIED WARRANTY OF MERCHANTABILITY OR FITNESS FOR A PARTICULAR PURPOSE.

The foregoing limited warranty shall not be enlarged or affected by, and no liability or obligation shall arise from, **SenTech's** rendering of technical or other advice, or service, in connection with any of its equipment or parts. Employees, agents, distributors, retailers, and sales representatives are not authorized to make warranties. Oral or written statements made may them do not constitute warranties and shall not be relied upon.

REPLACEMENT OR REPAIR OF DEFECTIVE EQUIPMENT OR PARTS AS PROVIDED ABOVE IS THE ORIGINAL PURCHASER-USER'S SOLE AND EXCLUSIVE REMEDY FOR CONTRACT, WARRANTY, NEGLIGENCE, TORT OR STRICT LIABILITY CLAIMS FOR ANY LOSS, DAMAGE OR EXPENSE ARISING OR ALLEGED TO ARISE OUT OF THE DESIGN, MANUFACTURE, SALE, DELIVERY OR USE OF SUCH EQUIPMENT AND/OR PARTS. IN NO EVENT SHALL SENTECH BE LIABLE FOR ANY AMOUNT IN EXCESS OF THE PURCHASE PRICE OF THE EQUIPMENT, OR FOR LOSS OF USE OR PROFITS, LOSS OF BUSINESS INTERRUPTION, ATTORNEY'S FEES, OR CONSEQUENTIAL, CONTINGENT, INCIDENTAL OR SPECIAL DAMAGES CAUSED OR ALLEGED TO CAUSED IN WHOLE OR IN PART BY THE NEGLIGENCE, TORT, STRICT LIABILITY, BREACH OF CONTRACT, BREACH OF WARRANTY, OR OTHER BREACH OF DUTY OF OR BY SENTECH.

SenTech Corporation
5745 Progress Road
Indianapolis, Indiana 46241

THIS LIMITED WARRANTY IS NOT TRANSFERABLE.

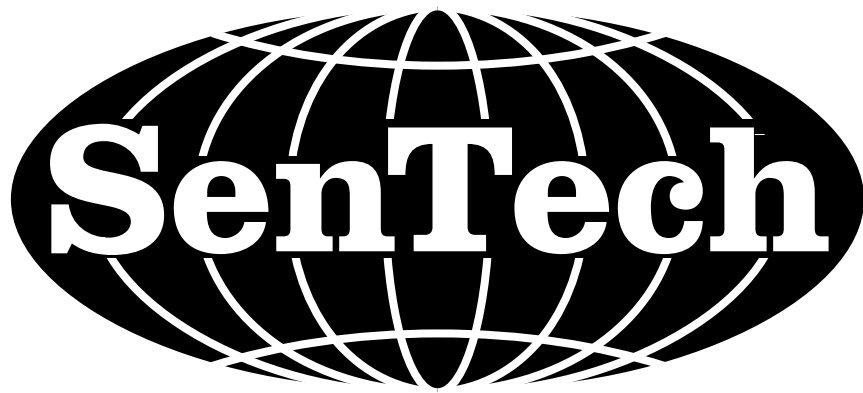

P/N SSG1
10-17-01