

INSTALLATION AND OPERATION MANUAL
ENVIRONMENTAL SYSTEM SSG-MCD
MODELS SSG-MCD1, 4, 8, 16

Contents

SAFETY PRECAUTIONS and WARNINGS	3
SPECIFICATIONS	4
INTRODUCTION/OVERVIEW	5
Basic Concept	5
Sensitivity	5
INSTALLATION	6
Location	7
Mounting and Tubing Installation	7
TB1 - Primary Power	7
TB2 - Alarm Relay Contacts	8
TB3 - Analog Outputs, External Reset, Serial Data	8
START-UP	9
Setup	9
FINAL CHECK	10
Monitor Sequencing	10
Alarm Test	11
Response to Refrigerant	11
End-to-End System Test	12
SYSTEM OPERATION	13
PREVENTIVE MAINTENANCE	14
APPENDIX A	15
Programming and Operator Interface	15
Startup Screens	15
Operational Screens	15
Momentary Screens	16
Menu Screens	17
APPENDIX B	20
Room Volume Considerations (English)	20
Room Volume Considerations (Metric)	21
EXPLODED VIEW & PARTS LIST	22
WIRING DIAGRAM	23
TROUBLESHOOTING GUIDE	24
WARRANTY	26
ILLUSTRATIONS	
Fig. 1 Block Diagram	5
Installation Layout	6
Fig. 2 Primary Power Connection	8
Fig. 3 Alarm Relay Connection	8
Fig. 4 Analog Output, External Reset and Serial Data (Optional) Connection	8

SAFETY PRECAUTIONS and WARNINGS

The following general safety precautions and warnings must be observed during all phases of installation, operation, service and repair of the equipment. Failure to comply with these precautions, given here and elsewhere in the manual, violates safety standards of design, manufacture and intended use. SenTech assumes no liability for the customers failure to comply with these requirements.

Definitions of safety symbols used on equipment and in manuals.

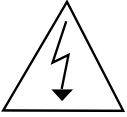

AC Voltage Terminal: Indicates areas of the equipment where AC line voltages are used and present a potential risk of electrocution. Areas using line voltages should not be accessed during operation.



Protective Grounding Terminal: The protective ground is to prevent electric shock in case of an electrical fault. This symbol indicates that the terminal must be connected to earth or ground before operation of the equipment.



Caution: This sign calls attention to a procedure or practice which, if not adhered to, could result in damage or destruction to a part of the product.

Input Power: Power should be supplied through a two pole circuit breaker located in reasonable proximity to the equipment. Ensure that the voltages are correct and an appropriate ground connection is provided.

Installation, Maintenance, and Repair: These functions should only be done by qualified personnel following the instructions outlined in this manual. This is Installation Catagory III equipment.

Pollution Degree: This equipment is designed for a Pollution Degree of 1.

Cleaning: The equipment should be cleaned by wiping with a soft clean cloth.

Intended Purpose: This equipment is designed to be used as a continuous refrigerant monitor. It should not be used for any other purpose.

Models SSG-MCD1, 4, 8, 16 Specifications	
Size:	16 1/2" X 15" X 6 3/4" (42 cm X 38.1 cm X 17 cm)
Weight:	32 lbs (14.4 kgs)
Power:	120/240 Volt (+/- 10%) 50/60 Hz (41 Watts)
Temperature:	32° - 125° Fahrenheit, (0° - 50° Centigrade)
Humidity:	0 - 95% non-condensing
Atmospheric Pressure:	75 - 106 KPa Equipment rated for indoor use only
Range:	0 - 1000 PPM Standard
Tube Length:	0-250 ft. (76 meters)
Rezeroing:	Automatic Standard
Zones:	Model SSG-MCD1 - 1 Zone Model SSG-MCD4 - 1 to 4 Programmable Model SSG-MCD8 - 1 to 8 Programmable Model SSG-MCD16 - 1 to 16 Programmable
Trip Point:	Low Alarm 0 - 100% of Full Scale Main Alarm 0 - 100% of Full Scale High Alarm 0 - 100% of Full Scale Horn Alarm Programmable to Low, Main or High
Leak Wait:	Varies from seven (7) seconds to three (3) minutes depending on gas concentration
Alarm Output:	Low, Main, High and Horn Alarm Relays Four (4) form C contacts rated 5 amps maximum
Analog Out:	0 to 10 VDC Standard 4 - 20 mA Optional
Computer Interface:	RS232 or RS485 Optional

INTRODUCTION/OVERVIEW

The SenTech Environmental System Suppression System Guard, Models SSG-MCD1, 4, 8 and 16 provide an early warning of developing fire suppression agent and refrigerant leaks. The unit sequentially samples the ambient air in each selected zone and measures the amount of halogen based gas in the air sample. When the proportion of gas present exceeds a trip point, the system goes into Alarm Mode notifying the user. By discovering a leak shortly after it starts, the potential loss can be reduced to ounces of refrigerant, saving money and helping protect the environment.

Basic Concept

Refer to the Block Diagram, (Fig. 1). Tubing from each area to be monitored is connected to the input manifold. The electronics sequentially energize the solenoid valves for each zone. The diaphragm pump draws air from the selected zone through the 5 micron filter assembly, the orifice, the infrared bench, and then to the exhaust port. The solid arrows show the air flow for normal operation.

The Infrared Bench has a source of IR energy at one end and a filter/detector at the other. Refrigerant present in the sample air will cause a decrease in the output of the detector. This change in signal is analyzed by the electronics and converted into a digital PPM (parts per million) level. The PPM level is compared to the trip points for that zone. If the PPM exceeds the Low Trip point, the Low Alarm Relay will be energized. If the signal continues to increase, the Main Alarm will be energized and ultimately the High Alarm. Once the system enters Low, Main or High Alarm for any zone, it will remain in that mode until the problem is cleared and the system is reset.

Sensitivity

The system is sensitive, in varying amounts, to all of the halogen based refrigerants, those that contain molecules of

either fluorine, chlorine or both. As part of the setup, the specific refrigerant to be monitored by each zone is entered into the system. The computer control compensates for the differing sensitivities, resulting in a true PPM reading for the refrigerant in the zone being tested.

The SSG-MCD system maintains accuracy through its automatic rezeroing capability. Periodically, the system switches to the Fresh Air inlet, and re-establishes its baseline level.

There is no direct relationship between the amount of gas leaking and the concentration level being measured. The size of the room, the location of the pick up point relative to the leak point, and the air pattern, all will affect the actual concentration at the inlet. However, by judicious location of the inlets (see installation section) and maintaining the trip point at a level not too far above the ambient, leaks should be detected substantially before they otherwise would be noticed. See Appendix B for a detailed discussion of room volume considerations.

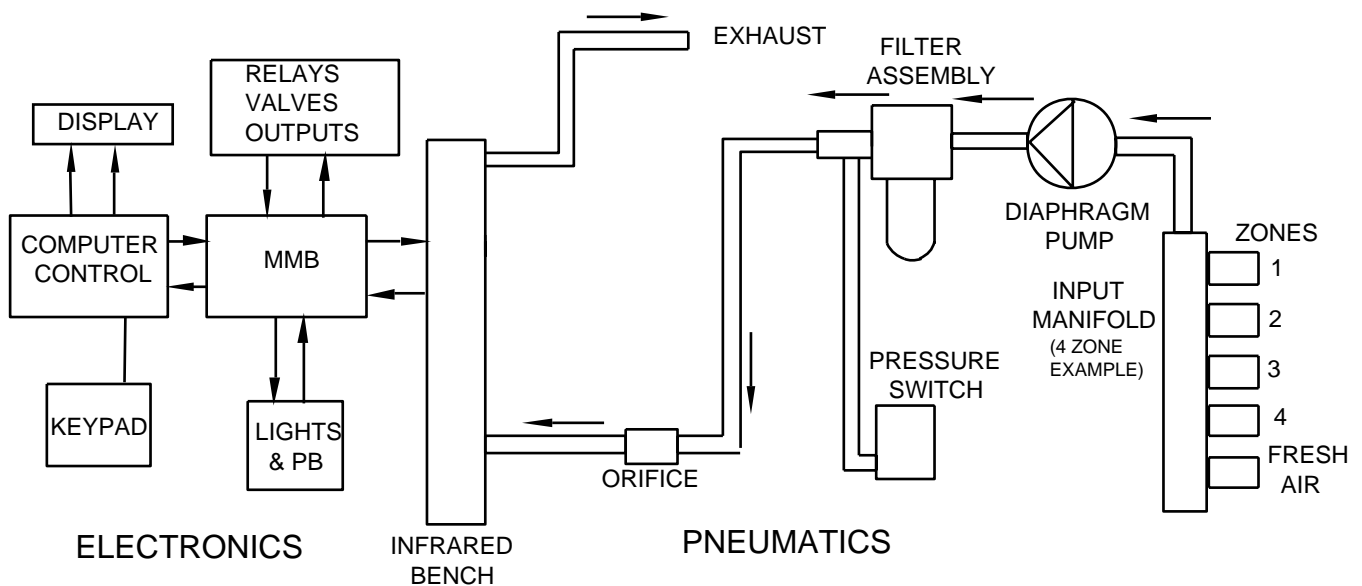
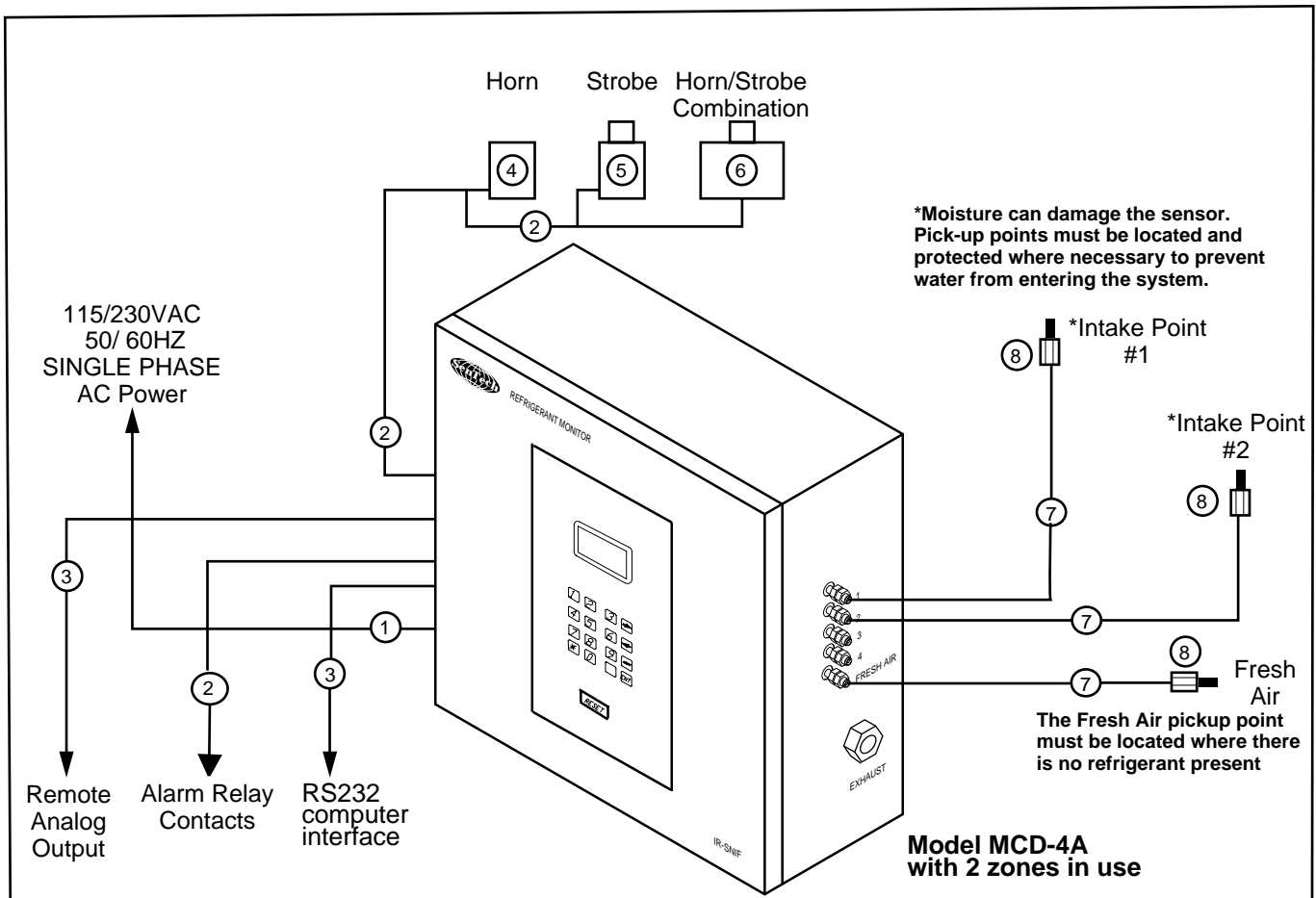

Fig. 1
System Block Diagram



**Model MCD-4A
with 2 zones in use**

Item	Description	Required	Supplied with Unit	Supplied by Customer	Optional	Available from SenTech	Comments
1	16 Gauge, 3 Conductor Cable	yes	no	yes		no	
2	18 or 22 Gauge, 2 Conductor Cable	no			yes	no	Required for horn, strobe or combination
3	2 Conductor Twisted Pair Shielded Cable	no			yes	no	Required for remote analog output
4	Horn	no			yes	yes	
5	Strobe Light	no			yes	yes	
6	Combination Horn and Strobe	no			yes	yes	
7	1/4" OD X 1/8" ID Plastic Tubing (recommend flame retardant, smoke resistant)	yes	no			yes	Available in 250 foot reels
8	Coarse Filter	yes	yes				For mounting at the end of the tubing

SERIES IR-MCD INSTALLATION LAYOUT

INSTALLATION

Material Required

Packed with the system:

1. This manual.
2. Coarse tube end filters (p/n 410144, one for each zone, plus fresh air).
3. The CTS/Warranty card, which is to be completed and returned after start-up.

User supplied or optionally purchased:

1. Plastic (FRPE) tubing 1/4" OD for the remote pickup points and fresh air inlet.
2. Horns, lights or other warning devices.
3. Wire for primary power and alarm devices.

(Refer to the MCD Installation Layout on page 6 for an overview of installation requirements.)

Location

Since the monitor measures the concentration of refrigerant in the air, each zone pick up point should be mounted where it is most likely to sense leaking refrigerant. The criteria to consider in selecting a location are as follows:

1. Should be as close to the area of potential leaks as possible. On the "downstream" side of the air flow pattern in the room.
2. Since refrigerants are typically heavier than air, the pick up tubes should be terminated 18" (46 cm.) above the floor.
3. The control unit should be located so that the farthest pick up point will require no more than 250 feet (75 meters) of tubing. The Fresh Air inlet tubing can be longer if required.
4. The Monitor includes electronics and an infrared bench, the mounting point should be free from vibration to the extent practical.

CAUTION

MOISTURE CAN DAMAGE THE INFRARED BENCH. PICK UP POINTS AND THE FRESH AIR INLET MUST BE LOCATED AND PROTECTED WHERE NECESSARY TO PREVENT WATER FROM ENTERING THE SYSTEM.

Mounting and Tubing Installation

Drill the necessary holes and mount the unit.

Zone Pick Up Tubes

Install the 1/4" tubing from each zone pick up point to the zone inlet fittings on the right side of the control unit. It is

recommended that you start with zone 1 at the top, and continue in sequence until the tube for each zone is installed. Terminate the tubing with the coarse filters. **Note: Do NOT split or "T" a sample tube. To do so will defeat flow monitoring routines in the unit. It is impossible to ensure correct air flow from split tubing, and thus impossible to ensure correct level readings in the areas connected to a single zone.**

Fresh Air Pick Up Tube

Since the fresh air input is the means by which the system maintains its accuracy, **it must be located at a point that cannot be reached by any leaking gas.** Install the tube for fresh air from the Fresh Air inlet at the bottom of the input manifold to a point outside the area being monitored. Terminate the tube with a coarse filter.

Suggested locations are:

An adjacent room, hallway, or office

Up into an air inlet duct

Outside the building (**As long as you are very careful to protect it from rain or rain splash. Water will damage the infrared bench.**)

CAUTION

ALL INSTALLATION WIRING, SERVICE AND MAINTENANCE SHOULD BE PERFORMED BY A QUALIFIED ELECTRICIAN IN ACCORDANCE WITH NATIONAL AND LOCAL CODES.

TB1 - Primary Power Wiring

1. Verify that voltage jumpers on TB1 are set for the correct voltage. Refer to the primary power wiring diagram (Fig. 2).

Two jumpers are required for **120 vac** supply.

Jumper from TB1-4 to TB1-6

Jumper from TB1-5 to TB1-7

One jumper is required for **240 vac** supply.

Jumper from TB1-5 to TB1-6

CAUTION

FAILURE TO VERIFY CORRECT JUMPER SETTING CAN DAMAGE THE MONITOR.

2. Connect Primary Power to TB1 as shown in figure 2.

Connect Earth Ground to TB1-1.

Connect AC Hot to TB1-2.

Connect AC Neutral or Common to TB1-3.

It is strongly recommended that power be supplied from a 2 pole circuit breaker, located in reasonable proximity to the system. Power **MUST NOT** be supplied by plugging into a wall socket. The unit is a continuous monitor. If a wall socket is used, there is a risk that the unit will inadvertently be unplugged putting it off line.

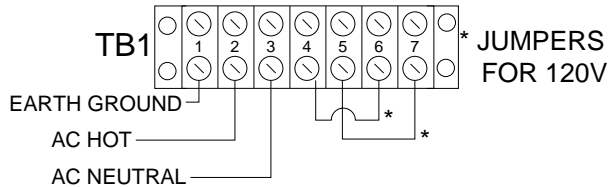
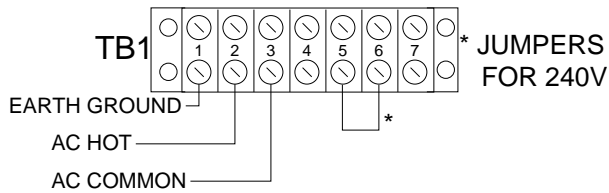

NOTE: UNITS FOR USE IN JAPAN ARE 100V/200V.

Fig. 2
Primary Power Connection

TB2 - Alarm Relay Contacts

1. Determine which external devices are to be connected to each of the Low Alarm, Main Alarm, High Alarm and Horn Relays. The Low, Main and High Alarm relays will be energized if any zone exceeds its programmed alarm threshold. The Horn relay will be energized when the monitor enters alarm. The Horn relay is programmable to activate when the Low Alarm activates, the Main Alarm activates or the High Alarm activates. (The factory default is to energize the Horn relay when the Main Alarm relay is energized.) The Horn relay is different from the alarm relays in that it can be silenced through the front panel "RESET" key, or via the remote reset connection on TB3

Warning lights, horns or other devices are actuated using the Alarm relay contacts on TB2 as shown (Fig. 3). Use an auxiliary contactor for heavy loads such as exhaust fans. **Note: Alarm contacts are rated (5) amps/240 VAC maximum.** (Refer to the system wiring diagram for a schematic of the alarm relays.)

2. Connect external devices to the alarm relays connected to TB2.

- Low alarm common connects to TB2-1
- Low alarm normally open connects to TB2-2
- Main alarm common connects to TB2-3
- Main alarm normally open connects to TB2-4
- High alarm common connects to TB2-5
- High alarm normally open connects to TB2-6
- Horn relay common connects to TB2-7
- Horn relay normally open connects to TB2-8

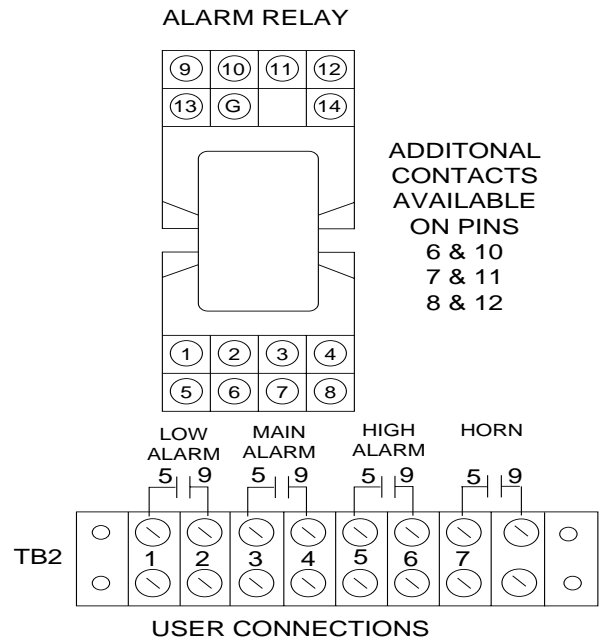

Fig. 3
Alarm Relay Connection

TB3 - Analog Output, External Reset, Serial Data

0-10 Volt DC Analog Output The 0-10 Volt DC analog output is available at TB3-1 (FIG. 4). TB3-1 is the positive side of the output and TB3-3 is the common or negative side of the output.

4-20ma Output (Optional) If the 4-20mA option has been purchased, the output is available at TB3-2 and TB3-3. TB3-2 is the plus current output and TB3-3 is the common.

External Reset An external reset connection is available at TB3-4. Reset is accomplished by providing an external momentary switch closure between TB3-4 Reset and TB3-3 common.

Serial Data (Optional) If the Serial Data option has been purchased, the output is available at terminals 5, 6 and 7 of TB3. Serial Data must be specified as RS232 or RS485 when ordering. TB3-5 is Transmit, TB3-6 is Ground, TB3-7 is Recieve.

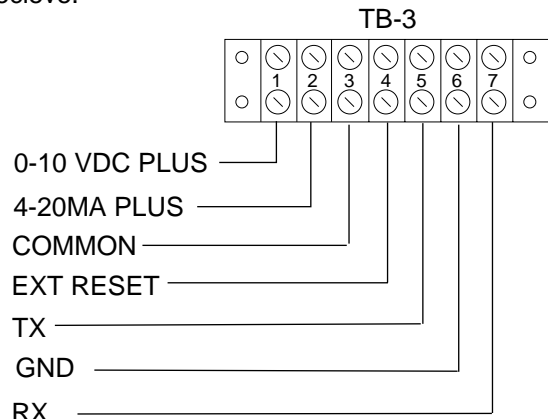

Fig. 4
Analog Out, Reset, Data

START UP

CAUTION

BEFORE PROCEEDING, DOUBLE CHECK YOUR WIRING.

Once installation has been completed, and wiring has been checked, close the door on the monitor and apply power to the monitor. The unit will now go through its normal start-up checks and warm-up procedure. It is important that the door remain closed during the warm-up procedure to ensure a proper warm-up of the monitor.

(If during start up a fault condition is detected, follow the instructions on the screen, and refer to the trouble shooting section of this manual.)

At the completion of warmup, the unit will be in Automatic Mode monitoring the first zone. The monitor will now be operating under the default settings it had when it left the factory. These may or may not be optimal for your installation.

SETUP

The setup procedures will allow you to set the system configuration (System Setup) and set the refrigerant monitoring parameters for each zone (IR Setup). For a detailed description of the Programming and Operator Interface, refer to Appendix A. A brief procedure is listed below.

The setup menus are accessed by pressing the "ENT" (enter) key on the front panel display of the monitor. Press the "3" key to enter Setup, followed by the password, "999". Upon entry of a correct password, the Setup menu will appear, giving 3 choices for subsequent menus (4 choices if the monitor is equipped with the 4-20 mA analog input option).

System Setup

From the Setup Menu, press the "3" key to enter System Setup. The System Setup menu will provide access to change passwords, set system flags, perform an alarm test and set the date and time.

System Flags

From the System Setup screen press the "2" key to display the System Flags screen. This screen will display:

- The Number of Zones
- The Password Flag
- The Horn relay Flag

Verify that the number of zones is correct for the model being installed. The factory default for the password flag is 0 and the default for the Horn Relay Flag is 2. (These are not normally changed. Refer to appendix A for complete descriptions of the functions to determine whether they should be modified.) Pressing "ENT" (enter) enters the current information and moves the cursor to the next entry.

After the last entry has been entered, the display exits the System Flag screen and returns to the System Setup screen.

Date and Time

From the System Setup screen, press the "4" key to enter the Date/Time screen. This screen will display four entries used to set the date and time.

- RTC Month
- RTC Day
- RTC Hour
- RTC Min

Enter the correct month by keying in the appropriate numbers. Note that the real time clock is based on a 24 hour or military time. (i.e enter 13 for 1 pm, 14 for 2pm, etc) Pressing "ENT" (enter) enters the current information and moves the cursor to the next entry. After the last entry has been entered, the display exits the Date/Time screen and returns to the System Setup screen.

On completion of System Setup, press the "ABORT" key to go back to the previous menu, or the Setup screen.

IR Setup

From the Setup Menu, press the "1" key to enter IR Setup. The IR Setup screen will provide access to check the list of available gas codes, modify the monitoring parameters for each zone and enable/disable measurement in each zone.

Gas Codes

From the IR Setup screen press the "1" key to access the list of Gas Codes. As of January 1, 2002 the standard SSG-MCD monitor is capable of detecting and responding to the following list of gasses.

R-11, R-12, R-13, R-22, R-113, R-114, R-123, R-134A, R-401A, R-401B, R-402B-HP81, R-404A-HP62, R-407A-AC9000, R-408A, R-409A, R-410A-AZ20, R-500, R-502, R-503, R-507-AZ50, HALON 1301, FM200

This list changes over time, so it is recommended that the operator review the Gas Code screens for a complete list of gasses a given monitor is capable of monitoring.

The Gas Code list is accessed by pressing the "1" key. the entire list of gasses can be viewed by pressing the left and right arrows to scroll from screen to screen. Once the appropriate gas codes have been determined, press the "ABORT" key to return to the IR Setup menu.

Zones

The Zone Enable/Disable screen is accessed by pressing the "3" key. This menu will allow the operator to select a zone and enable it or disable it. Pressing the left and right arrows will scroll from one zone to another. Pressing "ENT" (enter) enters the current information and moves the cursor to the next entry. Pressing "ABORT" saves the information and returns to the IR Setup menu.

Setup

The Setup menu to modify zone measurement parameters is accessed by pressing the "2" key. This menu consists of two screens that will allow the operator to select a zone and modify the gas, the sample tube length and the Low, Main and High alarm levels for each zone.

The first screen will display the zone, gas code and tube distance. Pressing the left and right arrows will scroll from one zone to another. Pressing "ENT" (enter) enters the current information and moves the cursor to the next entry.

Gas code: Set the correct gas code for the zone displayed. Note that different gas codes can be set for different zones.

Distance: Set the tube length for each zone. This will optimize the amount of time spent in each zone by entering the approximate length of tubing used for that zone. A rough "ball park" approximation is more than adequate for tube length. For single zone units, and multiple zone units with line lengths less than 100 feet, it is recommended that the tube length be set for 100 feet.

When the correct distance is entered, the cursor will move to the next screen to allow the operator to modify the Low, Main and High alarm settings.

Low Alarm Level: This will set the PPM level for a Low Alarm condition for that zone.

Main Alarm Level: This sets the trip point for Main Alarm.

High Alarm Level: This sets the trip point for High Alarm. It is recommended that this trip point be set at or near full scale.

When the High Alarm setting is entered, the cursor will move to the first screen of the next zone to allow the operator to continue. Once all of the zones are set, pressing "ABORT" saves the information and returns to the IR Setup Menu.

On completion of Setup, repeatedly press the "ABORT" key until the monitor returns to normal operation. The unit is now ready for final checks.

FINAL CHECKS

At this point, the system should have all the zones Setup, and it should be monitoring in Autosample Mode. There are four stages to the final checks: Correct Monitor Sequencing; Correct Integration with External Devices; Response to Refrigerant and End-to-End System Test.

MONITOR SEQUENCING

Watch the unit as it sequences through all the selected zones. Make certain that all the desired zones are on and the unused zones are off.

Make a note of the PPM readings in each zone. The reading should be less than 5 PPM. If, in any zone, the unit is reading 10 PPM or higher, or if it has gone into Alarm Mode, it is likely there is a leak present. A high reading may also result from the recent use of a chlorinated cleaning agent. Many industrial degreasers use chlorine based compounds. Examples are trichloroethylene or perchloroethylene. If you are convinced that there is no leak and that there are no other sources of halogen vapors in the room, contact SenTech.

INTEGRATION WITH EXTERNAL DEVICES

Once a monitor has been connected to external alarms, fans and building systems, integration can be checked by using the Alarm Test function of the monitor. The Alarm Test screen is found in the System Setup menus described previously in the START-UP section of this manual.

Alarm Test

The Setup Menu is accessed by pressing the "ENT" (enter) key on the front panel display of the monitor. Press the "4" key to enter Setup, followed by the password, "999". From the Setup Menu, press the "3" key to enter System Setup. From the System Setup Menu, press the "3" key to enter Alarm Test screen.

The Alarm Test screen is used to enable the installer to verify that the monitor is correctly integrated into the building systems.

The Low alarm is tested by pressing the "1" key.

The Main alarm is tested by pressing the "2" key.

The High alarm is tested by pressing the "3" key.

All alarms are tested by pressing the "4" key.

The Horn relay will be tested when the corresponding alarm relay is energized. For example, if the monitor is in the factory default, with the Horn relay triggered by the Main Alarm, the Horn relay will be energized when the "2" key is pressed.

Press the "4" key to test all alarm levels. This test will energize first, the Low relay, pause, energize the Main relay, pause and energize the High relay, so that at the end of the test, all of the relays are energized. This test will also energize the individual zone output relays (if so equipped).

Once any alarm relay is energized in the test mode, the screen will change to instruct the operator to press "RESET" to clear the test.

The Alarm Test screen is exited by pressing the "ABORT" key. This will reset all test relays and return the monitor to the alarm state prior to the test. On completion of the integration tests, press the "ABORT" key to exit each screen until the monitor resumes normal operation.

RESPONSE TO GAS

After checking all zones, the next step is to check for a proper response to the presence of a gas. This will be done by preparing a gas sample for testing, and then presenting it to the system to make certain it measures refrigerant. It is suggested you read through all the steps before starting. This test is best done after the monitor has been running normally for an hour or two.

Step 1: Select a zone and remove the inlet tubing from that zone.

Step 2: Prepare a refrigerant sample. Note that refrigerants and fire suppression agents can be Chlorofluorocarbons (CFC's), Hydrochlorofluorocarbons (HCFC's) or Hydrofluorocarbons (HFC's). HFC's are the only refrigerants considered to be truly "Ozone Friendly". Because of this, SenTech Corporation recommends use of an HFC, such as R134A or FM200 for field testing of the SSG-MCD series of monitors. Any field testing of a monitor, by its very nature, will release an amount of refrigerant into the environment through the exhaust port of the monitor.

CAUTION

FOLLOW ALL NATIONAL AND LOCAL CODES FOR SAFE HANDLING OF REFRIGERANTS.

Because the SSG-MCD is factory calibrated, and no field calibration is necessary, the gas sample is not required to be of a known level. A calibrated "test gas" kit is available from SenTech Corporation, should the user desire to perform the following tests with a sample of known PPM level. The following paragraphs describe a procedure for preparation of a sample using pure refrigerant.

Three items are needed to prepare a sample:

- A Refrigerant
- A Container
- A short piece of 1/4" Tube.

The Refrigerant should be available on-site, but if not, R-134A is readily available at local stores. Note that many local office supply stores sell a 'pressurized air duster'. Often, this product is simply pressurized Tetrafluoroethane, or R-134A. This is a cost effective, readily available source

of pure test gas, as long as the contents have been verified to be Tetrafluoroethane.

The sample container may also be available on-site. Suitable sample containers range from lab quality sealed bags with twist valves to a simple plastic bag or even an open top jar or can. The container should be at least 4 liters, or about a gallon. The container should be able to be loosely closed, e.g. twisting a plastic bag, or closing a lid.

The 1/4 inch tubing should be long enough to connect to the selected zone and extend into the bottom of the sample container. Because refrigerants are heavier than air, pulling the sample from the bottom of the container will ensure introduction of the refrigerant into the selected zone.

a) Gaseous Refrigerants: Insert a refrigerant fill hose into the container opening. Crack the valve for a second or less so that a small squirt of refrigerant enters. Keep in mind that the monitor reads in PPM (parts per million) and a tiny amount of gas will make a relatively high concentration sample. Pull out the hose, and loosely close the container.

b) Liquid Refrigerants: Open the container slightly and put in a few drops of liquid refrigerant. Loosely close the container and allow time for the refrigerant to gasify. A bag will expand some as the liquid evaporates.

CAUTION

DO NOT CLOSE A RIGID SAMPLE CONTAINER TIGHTLY, BECAUSE REFRIGERANTS EXPAND AND CAN CREATE PRESSURE. DO NOT ALLOW PRESSURE TO BUILD UP IN THE SAMPLE CONTAINER.

Step 3: Manual measurement of sample. Switch the monitor to manual override for the selected zone. The Manual Override menu is accessed by pressing the "ENT" (enter) key on the front panel display of the monitor. Press the "3" key to enter Manual Override. Press the Number of the selected zone, followed by the "ENT" (enter) key. Place the 1/4 inch tube into the sample container and connect it to the selected zone to simulate a concentration of refrigerant in the air.

CAUTION

NEVER CONNECT A PRESSURIZED REFRIGERANT BOTTLE DIRECTLY TO THE MONITOR. THE UNIT IS DESIGNED TO OPERATE ONLY AT ATMOSPHERIC PRESSURE. DOING SO CAN DAMAGE THE UNIT.

After approximately 5 seconds, the PPM reading should start to rise. Within 30 to 45 seconds, the PPM level should

level off. A sample prepared as described in step 2 should easily contain more than 150 PPM. If the PPM reading does not rise above the highest alarm setting in the monitor, repeat the sample preparation procedure with a larger amount of refrigerant. Readings of 150 or higher indicate a successful test of the monitor's ability to sense refrigerant. Disconnect the sample from the monitor and save for the next step. The sample container should now have a measured concentration of refrigerant greater than the highest alarm level. This will be used to test the end-to-end performance of the system in the next step.

Once the sample tube has been disconnected from the monitor, the readings should fall slowly down to at or near zero PPM. When the PPM level reaches near zero, press the "ENT" (enter) key to exit Manual Override and return to normal operation.

END-TO-END SYSTEM TEST

After manually verifying the operation of the monitor, and obtaining (creating) a sample known to have a PPM level higher than the highest alarm, the next step is to perform an end-to-end test of the system. This test will verify that the monitor will correctly trigger alarms and the external devices connected. This will be done by connecting the sample of refrigerant from the previous test to a selected zone and observing the alarms. This test is best done after the monitor has run through at least two complete zones and two autozero cycles.

On multiple zone units, a convenient method to ensure the monitor has been through at least two cycles is to connect the sample to the same zone selected above and wait for the monitor to cycle through all of the enabled zones.

Once the monitor reaches the selected zone, watch the PPM reading. After approximately 5 seconds, the PPM reading should start to rise. When the monitor exceeds the alarm threshold, it will switch to "Leak Wait" mode. This mode ensures the presence of a leak before triggering an alarm. The leak wait period can be as short as 7 seconds and as long as 3 minutes. **Note: The more the reading exceeds the alarm trip point, the shorter the time to enter alarm.** The system should progress from Low alarm, through Main alarm and into High alarm. **Note: If the monitor exceeds high alarm while in leak wait, it will appear to trigger Main alarm and High alarm at the same time. This is normal, correct operation.**

When the Horn relay energizes, the external horn should sound (if so equipped) and the bottom line of the display should change to "RESET to Silence". This instructs the operator to push the "RESET" key to silence the Horn.

If the Horn has been silenced, the fourth line of the display should change to "RESET to Clr Alarms". This instructs the operator to clear the alarms.

Remove the gas sample from the inlet and wait until the PPM reading drops back to normal. Push the "Reset" button. The System should clear the alarms and be back in normal Automatic operation.

Reconnect the zone inlet tube and dispose of the gas sample in an appropriate manner.

DOCUMENTATION

Initial and date the inspection sticker on the inside front cover of the unit.

Fill out the CTS/Warranty form completely and return it to SenTech in the envelope provided. This is an important step to establish warranty. Please use this opportunity to make any suggestions for improvements.

If you are part of the user organization, store this manual in a safe place. If you are an installing contractor, please turn over the manual to the user.

If you need any additional manuals, call SenTech and we will be pleased to provide them at no charge (make a note of the unit serial number when requesting a manual). Installation and Operation Manual of every Monitor ever produced by SenTech Corporation are available at the SenTech website:

www.sentechcorp.com

Basic installation and start-up is now complete. The unit should be on line and monitoring.

The remainder of this manual includes further information on operational characteristics, programming, preventive maintenance, trouble shooting, parts lists, and a detailed wiring diagram.

SYSTEM OPERATION

The normal state of the SSG-MCD system will be Automatic mode, cycling through the zones, sampling the air, and sensing for leaks. The state of the system, the zone it is in, and the PPM level will be displayed on the front panel display.

After applying power (or after a temporary power outage) the system will revert to the Start-Up Mode. If the system has been switched to some other mode such as Manual, after some time delay, it will revert to Automatic. The only exception is Fault Mode. Once a Fault is detected, it will remain in Fault until the problem is corrected and there is a manual reset.

START-UP MODE

When the system first enters Start-Up Mode, it will go through several steps before entering full automatic operation. For a detailed description of all the screens and operator interface options, turn to Appendix A "Programming and Operator Interface".

ID Screen

The first screen will be an identification screen, which will last for a few seconds.

Optics Warm-Up

The second screen will display that the monitor is waiting for the infrared bench to warm-up. When the warm-up is complete, the system will switch to:

Automatic Rezeroing

During this step, the monitor will be drawing its sample from the Fresh Air input port. During Automatic Rezeroing the screen will count down the time remaining. The system electronics will use the sample time to establish the zero signal, or baseline level. When the monitor is sampling the active zones, it compares the zone signal to the zero signal to determine the concentration of refrigerant.

Periodically, during the course of normal operation, the monitor will automatically rezero itself to maintain its accuracy. When it completes the automatic rezero step, the system will switch to:

Auto Sampling

At this point, the monitor will be sampling the selected zones, checking for leaks.

During Auto Sampling, the system will display the zone being monitored and the refrigerant concentration level in PPM (parts per million). When the system enters Auto Sampling, it starts with the first selected zone. When it completes sampling the first zone, it will Rezero and then switch to the next selected zone. After it completes sampling all the selected zones, it will switch back to the first selected zone and repeat the process. The amount of time spent in each zone will be a function of the tube length

entered for that zone. For a single zone unit, the monitor will continuously sample the one zone (except for periodic rezeroing).

ALARM STATUS SCREEN

WHEN THE SYSTEM DETECTS AN ALARM IN ANY ZONE, IT STORES THAT INFORMATION IN AN ALARM STATUS SCREEN. TO DETERMINE WHICH ZONES ARE IN ALARM AND THE LEVEL OF ALARM:

Enter "#"

Enter "1" for Zone Alarms

Step through the screens to determine the Zones in alarm and the level of Alarms for each zone.

Low Alarm

If the PPM level for the monitored zone exceeds the Low Alarm trip point, the monitor will enter Low Alarm Mode. The Low Alarm relay will be energized, the Alarm LED will be energized, and the system will store a Low Alarm for that zone. Once the Low Alarm relay is energized for any zone, it will remain energized until there is a Manual Reset (this holds for any of the alarm states).

Once the system enters Low Alarm, it will extend the period of time for that zone, to determine if the concentration will increase to the next level of alarm. If during this additional time the PPM level remains below the next trip point, the system will switch to the next zone.

Main Alarm

If the Main Alarm trip point is reached or exceeded, the system first goes through a leak wait period. This is to confirm that an actual Main Alarm has occurred, rather than a short term transient event. The length of the wait period depends upon the difference between the concentration level and the Main Alarm trip point. The larger the signal, the shorter the wait time.

If the concentration level falls below the Main Alarm trip point for a few seconds, the system will assume it was a transient, and switch to the next zone.

If the signal remains above the trip point during the wait period, the system will enter Main Alarm Mode, and the Main Alarm relay will be energized, and remain energized until a Manual Reset. The system will store the alarm status as Main. Once the Main Alarm is determined, the system will add an additional period of time for the zone. This is to determine if the concentration level will continue to rise to the High Alarm trip point. If during this extension, the PPM level remains below the next trip point, the system will switch to the next zone.

High Alarm

Once the High Alarm trip point is reached, the system enters High Alarm Mode. The High Alarm relay is energized and

remains energized until a Manual Reset. The System will store the alarm status as High. The system will then switch to the next selected zone and proceed with the Auto Sampling process.

FAULT MODE

If ,at any time, the system detects a fault condition, it will enter Fault Mode. The Main Alarm relay will energize. The display will indicate the type of fault detected. All monitoring will stop and the system will remain in Fault Mode until there is a Manual Reset.

Refer to the "Trouble Shooting" section of the manual for a detailed description of the types of faults and the recommended action.

MANUAL MODE

Manual Mode is normally used only for troubleshooting and checkout, or when checking for a leak after an alarm condition has been detected.

Manual Mode is accessed by exiting from Automatic Mode and following the screen instructions. Manual Mode forces the monitor to stay in the selected zone. In Manual Mode, the screen will display the selected zone and the PPM level.

When browsing through the zones, allow 5 or 10 seconds for the PPM level to adjust to that of the new zone. If conditions are changed at the end of a long tube run, allow several minutes for a new air sample to reach the sensor, and the PPM level to stabilize.

When you have completed the desired checks in Manual Mode, exit to Automatic Mode to put the system back into normal operation.

Note: As a safety precaution, the system will automatically revert to Automatic Mode, after a period of time in which there have been no key strokes.

PREVENTIVE MAINTENANCE

The recommended periodic preventative maintenance is as follows:

Perform Quarterly Filter Inspection and replace as necessary.

Perform Quarterly Performance Verification.

Filter Inspection and Replacement

5 Micron Filter located in the plastic bulb at the upper right inside the monitor, should be replaced when it becomes discolored. It is normally white. Replace it when it turns gray from accumulated dust. After replacing the filter, be sure to tighten the plastic bulb to an air tight seal.

Coarse Filters (Tube End Filters) are located in each sample zone and fresh air zone on the ends of the 1/4 inch tubes. The Coarse Filters are sintered brass or bronze, and will naturally discolor to a dark bronze color. Inspect the filter for obvious clogging or build up of dust. Replace , rather than clean the filters.

Quarterly Performance Check: Once per quarter, perform the End-to-End system test described in the Final Checks Procedure on page 12.

APPENDIX A PROGRAMMING AND OPERATOR INTERFACE

SUMMARY

The operator interface is composed of four sets of screens:

START-UP SCREENS - Displayed when power is applied to the system.

OPERATIONAL SCREENS - Displayed for the multiple gas monitoring modes.

MOMENTARY SCREENS - Displayed in response to a key pressed to display additional information for the zone being monitored, or for analog input channel (if so equipped).

MENU SCREENS - Screens used to change the operational mode of the monitor, set the configuration of the refrigerant monitoring zones, set the configuration of the analog inputs from remote 4-20 mA sensors (If so equipped) and change system parameters for the monitor.

START-UP SCREENS

When power is applied to the system, it will step through a series of start-up screens.

Contact Screens

The Contact Screens display the company name, phone number and website. After a short pause, a second screen is displayed to identify the Model, Version and Options installed in the software of the monitor.

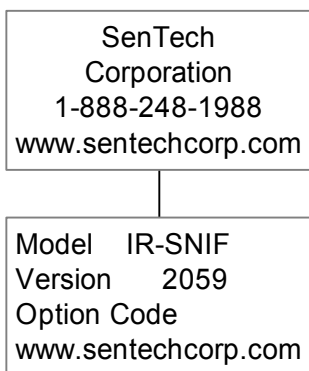

Optics Warm-Up

The Optics Warm-Up Screen is displayed while the monitor is stabilizing internal temperature. Currently this is set at about 9 minutes.

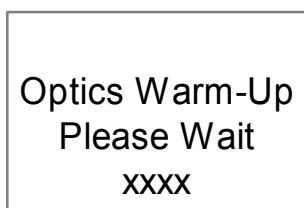

Copyright

The Copyright screen will be displayed on completion of Optics Warm-Up. After a short pause, the monitor will begin normal operation.

```
graph TD; A["SenTech IR-SNIF  
Refrigerant Monitor  
Copyright (c) 2001"]
```

OPERATIONAL SCREENS

When the monitor completes Start-Up, it will enter Autozero, then proceed to measure the first zone in Autosample mode. Under normal circumstances the monitor will cycle from Autozero to Autosample, stepping from zone to zone. If an alarm condition is detected the monitor will enter Leak Wait mode to ensure a leak is detected. If the operator manually overrides the autosample operation, the monitor will display Manual Override until the operator exits manual operation or the monitor time outs and returns to normal operation.

Autozero

Autozero measures the fresh air (refrigerant free) zone between each zone. Autozero takes approximately 24 seconds under normal conditions. If the monitor senses a high concentration of refrigerant, the Autozero measurement time is extended to approximately 45 seconds.

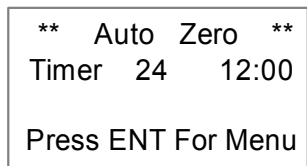

Auto Sampling

Autosample mode is the normal measurement mode of the monitor. It displays the zone being measured, the PPM level in that zone and the current time. If the Horn relay has been energized, the fourth line will instruct the operator to press the "RESET" key to silence the horn. If the monitor is in alarm, the fourth line will instruct the operator to press the reset key to clear alarms.

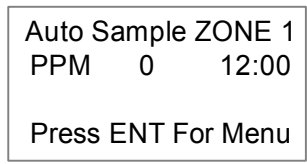

Leak Wait

When the monitor is in Autosample mode and first senses a change in PPM, it enters Leak Wait mode. This ensures the monitor truly detects a leak before activating the Low Alarm relay and the Main Alarm relay. The length of the wait period depends upon the difference between the concentration level and the alarm trip point. The larger the difference, the shorter the wait time. If the concentration falls below the alarm trip point, the system will determine that it was a transient, and return to normal operation.

```
Leak Wait  ZONE 1
PPM    0    12:00

Press ENT For Menu
```

Fault Mode

When the monitor detects a fault condition, it will enter fault mode. The Main relay will energize and "Trouble Alarm" will be displayed in the third line of the display.

```
Auto Sample ZONE 1
PPM    0    12:00
    Trouble Alarm
Press ENT For Menu
```

Alarm Modes

When the monitor has sensed concentrations above the alarm trip points, the associated relays will be energized. The Low, Main and High relays will be energized if any zone has exceeded the corresponding alarm levels. The Horn relay will be energized depending on its programming. The monitor can be set up to energize the Horn relay when the Low alarm is activated, the Main alarm is activated or the High alarm is activated. This is programmed via the System Setup menus described later in this document.

If an alarm is activated, the fourth line in the operational screens will change to instruct the operator how to clear the alarm. When the "RESET" is pressed, the monitor will switch directly to the Alarm Status screen described on page 18.

Clear Alarm

```
Auto Sample ZONE 1
PPM    0    12:00

RESET To Clr Alarm
```

If the monitor has also energized the Horn relay, it can be silenced by pressing the "RESET" key. The fourth line in the operational screens will change to instruct the operator how to silence the Horn. When the alarm condition is cleared, the Horn is enabled and will be activated should another alarm

occur.

Silence Horn

```
Auto Sample ZONE 1
PPM    0    12:00

RESET To Silence
```

Manual Override

Manual Override mode is useful to temporarily measure a selected zone. It displays the zone being measured, the ppm level in that zone and the current time. Alarm processing is suspended during Manual Override. Manual Override mode is entered via the menus described later in this document.

```
Manual Override  1
PPM    0    12:00

Press ENT To Exit
```

MOMENTARY SCREENS

The monitor has a series of Momentary Screens accessed simply by pressing a key. Key "1" corresponds to the refrigerant channel, or one of the multiple channels. Keys "2" through "5" correspond to the four 4-20 mA analog input channels for remote sensors (if so equipped), or channels 2 through 5 of the monitor.

Key "1" - Displays refrigerant for zone being monitored in third line of display.

```
Auto Sample ZONE 1
PPM    0    12:00
R-134A
Press ENT For Menu
```

Key "*"** - Pressing the "***" key will momentarily display the contact and monitor configuration information displayed in the Start-Up Screens.

```
SenTech
Corporation
1-888-248-1988
www.sentechcorp.com
```

```
Model IR-SNIF
Version 2059
Option Code
www.sentechcorp.com
```

MENU SCREENS

The Menu Screens can be accessed from any Operational Screen by pressing the "ENT" or enter key. In the first menu, the operator is given the choice to review Zone Alarms, manually perform an Autozero, enter Manual Override mode or enter Setup.

```
1)...ZONE Alarms
2)...Rezero
3)...Manual
4)...Setup  ABORT
```

Alarm Status

The Alarm Status Screen is accessed by pressing the "1" key. If any zones are in alarm, the operator will have access to a series of screens formatted to show the zone, the alarm level, the peak reading in that zone, and the time and date of the alarm. Additional alarm screens can be accessed by pressing the left and right arrow keys. If there are no alarms to display, or the last alarm has displayed, "No More Alarms". If the "RESET" or "ABORT" keys are pressed, the monitor will exit and return to normal operation.

```
Alarm Status
ZONE 1 LOW PK 36
03/06 12:00
<- RESET or ABORT ->
```

Once all of the zones in alarm have been displayed, the Monitor will check for Trouble Alarms. Trouble Alarms will be generated if the monitor senses a fault in the Infrared Bench (sensor), a fault in the remote reset connection and a flow related failure. A flow related failure will be reported as a possible pump failure, and flow failures in any given zones. This is helpful in determining whether the problem is isolated to a zone or is internal to the monitor.

The Bench Voltage trouble alarm will be displayed if the monitor senses a fault in the Infrared Sensor.

```
Trouble Alarm
Bench Voltage
Call Factory
<- RESET or ABORT ->
```

The Remote reset trouble alarm will be displayed if the remote reset connection detects a shorted circuit. This is helpful to prevent malfunctions in the operation of the monitor caused by external connections.

```
Trouble Alarm
Remote Reset
Check For Short
<- RESET or ABORT ->
```

The Pump Failure Possible trouble alarm will be displayed if the monitor detects a flow failure.

```
Trouble Alarm
Pump Failure
Possible
<- RESET or ABORT ->
```

The Zone Flow Failure trouble alarm will be displayed for any zone measured while a flow failure exists. This is helpful in identifying a malfunction in a valve, or a blocked line in a zone.

```
Trouble Alarm
Flow Failure
Check Zone 1
<- RESET or ABORT ->
```

Rezero

The monitor can be switched into Autozero Mode manually by pressing the "2" key. On completion of the manually initiated Autozero, the unit will return to normal operation.

```
** Auto Zero **
Timer 24 12:00

Press ENT For Menu
```

Manual Override

The Manual Override Screen is accessed by pressing the "3" key. The operator will have the ability to manually enter any enabled zone to monitor.

```
Manual Override
AREA 1
ENTER AREA NUMBER
FOLLOWED BY ENT
```

Once the zone is entered, the unit will switch to Manual Override. The unit will return to normal operation if the "ENT" (enter) key is pressed, or after approximately 15 minutes, whichever comes first.

```
Manual Override 1
PPM 0 12:00

Press ENT To Exit
```

Setup

The Setup Menus are accessed by pressing the "4" key. The operator will be asked to enter a password to continue into the Setup Menus. There are five passwords. Passwords 1 through 4 are user definable (default passwords are "111", "222", "333", "444"). The last password is permanently set at "999".

```
* SenTech Monitor *
ENTER PASSWORD
Followed by ENT
Code:    XXX
```

If the correct password is entered, the unit will display the Setup Menu Screen. From the Setup Menu, the operator can access the refrigerant monitoring settings (IR Setup), the analog input settings (4-20 mA Setup - If so equipped), system configurations settings and the contact screen. Refer to the 4-20 mA addendum to the manual for programming information.

Setup Menu (w/o 4-20 input option)

```
1)...IR Setup
2)...N/A
3)...System Setup
4),,,Contact ABORT
```

Setup Menu (w/4-20 input option)

```
1)...IR Setup
2)...4-20 mA Setup
3)...System Setup
4),,,Contact ABORT
```

IR Setup

The IR Setup screen is accessed by pressing the "1" key. This menu will give the operator access to a list of all refrigerants programmed into the monitor (Gas Codes). The operator will be able to change the setup for each zone (Setup), and to Enable and Disable specific Zones (Zones).

```
Determine Gas Codes
FOR Each ZONE
1-Gas Codes  2-Setup
3-ZONES      ABORT
```

Gas Codes

As of January 1, 2002 the standard IR-SNIF monitor is capable of detecting and responding to the following list of refrigerants.

- R-11, R-12, R-13, R-22, R-113, R-114, R-123, R-134A,
- R-401A, R-401B, R-402B-HP81, R-404A-HP62,
- R-407A-AC9000, R-408A, R-409A, R-410A-AZ20, R-500,
- R-502, R-503, R-507-AZ50

This list changes over time, so it is recommended that the operator review the Gas Code screens for a complete list of gasses a given monitor is capable of monitoring.

The Gas Code list is accessed by pressing the "1" key. the entire list of gasses can be viewed by pressing the left and

right arrows to scroll from screen to screen. The initial screen is shown below.

```
Gas Code Selections
1-R11      2-R12
3-R13      4-R22
          ABORT  ->
```

Setup

The Setup menu is accessed by pressing the "2" key. This menu consists of two screens that will allow the operator to select a zone and modify the Gas, the sample tube length and the Low, Main and High alarm levels for each zone. Pressing the left and right arrows will scroll from one zone to another. Pressing "ENT" (enter) enters the current information and moves the cursor to the next entry. Pressing "ABORT" saves the information and returns to the previous menu.

```
ZONE  1  <- ->
Gas    2
Distance 100
          ENT or ABORT
```

```
Alarm LOW    25
Alarm MAIN   50
Alarm HIGH   500
          ENT or ABORT
```

Zones

The Zone Enable/Disable screen is accessed by pressing the "3" key. This menu will allow the operator to select a zone and enable it or disable it. Pressing the left and right arrows will scroll from one zone to another. Pressing "ENT" (enter) enters the current information and moves the cursor to the next entry. Pressing "ABORT" saves the information and returns to the previous menu.

```
ZONE  1  <- ->
Status  1
1-Enable 0-Bypass
          ENT or ABORT
```

System Setup

The System Setup menu is accessed from the Setup menu by pressing the "3" key. The System Setup menus allow the operator to change passwords (Change Code), change system configuration (System Flags), test alarm relays (Alarm Test) and set Time/Date.

```

1)...Change Code
2)...System Flags
3)...Alarm Test
4)...Date/Time ABORT

```

```

Alarm Test
1)...Low    2)...Main
3)...High   4)...All
Press Key to Test

```

Change Code

The operator can change passwords 1 through 4 by pressing the "1" key. The operator then enters the code number (1-4) and is able to enter the new password.

```

Select Code # To
View Or Change Code

Access Code #  1

```

```

Access Code #  1
Code          111

ENT - Exit

```

```

Alarm Test
1)...Low    2)...Main
3)...High   4)...All
RESET to CLEAR

```

Date/Time

The Date/Time menu is accessed by pressing the "4" key. This menu will allow the operator to enter the Month, Date, Hour and Minute stored by the real time clock in the processor. Note that Time is based on a 24 hour clock, or military time. Pressing "ENT" (enter) enters the current information and moves the cursor to the next entry. Pressing "ABORT" saves the information and returns to the previous menu.

```

RTC Month      3
RTC Day        5
RTC Hour       13
RTC Min        25

```

System Flags

The System Flags menu is used to change miscellaneous settings. This menu is used to change the number of zones when the unit is built. This is only changed if the operator performs a field upgrade of the number of zones on the unit. This menu is also used to set whether a password is required to access the first menu screen. A password is always required for Set Up menus. Setting the password flag forces the operator to enter the password to access ALL menu screens. This is useful in areas where unauthorized personnel may have access to the monitor. Last, this menu is used to set the Horn relay flag. The Horn relay flag determines the alarm that triggers the Horn relay. 1 = Low alarm, 2 = Main alarm and 3 = High Alarm.

```

ZONES      16
PASSWORD FLAG  0
HORN RELAY FLAG  2

```

Alarm Test

The Alarm Test screen is used to enable the installer to verify that the monitor is correctly integrated into the building systems. The Low alarm is tested by pressing the "1" key. The Main alarm is tested by pressing the "2" key. The High alarm is tested by pressing the "3" key. The Horn relay will be tested when the corresponding alarm relay is energized. For example, if the monitor is in the factory default, with the Horn relay triggered by the main alarm, the Horn relay will be energized when the "2" key is pressed. All alarms are tested by pressing the "4" key. This will energize first, the Low relay, pause, energize the Main relay, pause and energize the High relay, so that at the end of the test, all of the relays are energized. Once any alarm relay is energized in the test mode, the screen will change to instruct the operator to press "RESET" to clear the test. The Alarm Test screen is exited by pressing the "ABORT" key. This will reset all test relays and return the monitor to the alarm state prior to the test.

Appendix B: SenTech Room Volume Considerations (English)

Normal industry practice is to think about refrigerant leaks in terms of pounds of refrigerant per unit time such as lbs/hr or ozs/yr. This is a natural and logical way of looking at it. The system monitors the amount of refrigerant present in the air in Parts Per Million (PPM) by volume of refrigerant molecules as compared to air molecules. In order to develop a relationship between the leak rate in weight per unit time and ppm reading of the monitor, there are a number of items that need to be considered and accounted for. These are:

1. Room Volume.
2. The relationship between refrigerant amount in weight compared to refrigerant volume at the temperature and pressure of the room.
3. The amount of time the refrigerant has been leaking.
4. The rate at which fresh air enters the room (stale air is exhausted).
5. The location of the monitor inlet relative to the leak, the air patterns of the room, and the rate at which the leaking refrigerant expands to fill the room.

For a given specific situation items 1 through 4 are either known, can be calculated, or can be estimated. Item 5 is virtually unknowable, therefore in all the formulas and sample calculations it is assumed that leaking refrigerant expands immediately to fill the room. This is a reasonable and conservative assumption on the basis that you have located the monitor following the recommendations outlined in the installation section. If you have followed those recommendations, the monitor should see a higher concentration sooner than the idealized formulas.

The equations have been developed for two cases. **Case I** is for a sealed room, no air turnover. **Case II** is for a room with a known turnover of air.

To be able to convert between a leak rate in cubic feet per hour to a leak rate in pounds per hour the molecular weight of the refrigerant needs to be known. If you know the molecular weight of the refrigerant, you can calculate the necessary conversion factors at normal atmospheric pressure and room temperature.

$$\frac{\text{Mol Wt(gms)}}{1(\text{mole})} \times \frac{1(\text{mole})}{22.4(\text{ltrs})} \times \frac{1(\text{pound})}{454(\text{gms})} \times \frac{28.32(\text{ltrs})}{1(\text{cuft})} \times \frac{273}{293} = \frac{\#}{\text{cuft}}$$

Substituting for R-22 (86.48 grams/mole), you get $0.22 \frac{\#}{\text{cuft}}$.

Conversion Factors for Common Refrigerants

R-22	.22 #/cuft	4.46 cuft/#
R-12	.31 #/cuft	3.18 cuft/#
R-11	.36 #/cuft	2.80 cuft/#
R-502	.29 #/cuft	3.45 cuft/#
R-123	.41 #/cuft	2.41 cuft/#

PPM READINGS AND LEAK RATE RELATIONSHIP DEFINITIONS:

- PPM = Monitor PPM reading or trip point PPM setting
- LR = Leak Rate of refrigerant in cubic feet per hour
- FA = Fresh Air into the room in cubic feet per hour
- VOL = Volume of the room in cubic feet
- t = Time in hours (There are 8760 hours in one year)
- R = Amount of refrigerant in the room in cubic feet
- LR_{min} = Minimum leak rate that will reach a given PPM

Case I: Sealed Room

$$\text{PPM} = \frac{\text{LR} \times t \times 10^6}{\text{VOL}} \quad t = \frac{\text{PPM} \times \text{VOL} \times 10^{-6}}{\text{LR}}$$

$$R = \text{PPM} \times \text{VOL} \times 10^{-6}$$

Case II: Room with Air Changing

$$\text{PPM} = \frac{\text{LR}}{\text{FA}} (1 - e^{-\frac{\text{FA}}{\text{VOL}} t}) 10^6$$

$$t = \frac{\text{VOL}}{\text{FA}} \times \ln \left(\frac{\text{LR}}{\text{LR} - \text{PPM} \times \text{FA} \times 10^{-6}} \right)$$

$$\text{LR}_{\min} = \text{PPM} \times \text{FA} \times 10^{-6}$$

Sample Calculations (Assuming The room is 40 feet by 30 BY 10 feet = 12,000 cuft)

Case I: Sealed Room

1. How much R-22 is necessary to cause a 25 ppm reading ?

$$R = 25 \times 12000 \times 10^{-6} = .3 \text{ cuft}$$

$$.3 \text{ cuft} \times .22 \text{ lb/cuft (R-22)} = .066 \text{ lbs}$$

2. If the leak rate is 300 lbs./year of R-22, how long will it take to reach 25 ppm ?

$$\frac{300 \text{ lbs}}{\text{yr}} \times \frac{1 \text{ yr}}{8760 \text{ hr}} \times \frac{4.46 \text{ cuft}}{\text{lbs}} = .153 \text{ cuft/hr}$$

$$t = \frac{25 \times 12000 \times 10^{-6}}{.153} = 1.96 \text{ hrs}$$

Case II: Room with Air Changing

Assume the same room 12,000 cuft.
Assume fresh air at 100 cfm or 6000 cuft/hr (1 air changes in 2 hour).

1. For R-22, what is the minimum leak that will reach 25 ppm ?

$$\text{LR}_{\min} = 25 \times 6000 \times 10^{-6} = .15 \text{ cuft/hr}$$

$$.15 \text{ cuft/hr} \times .22 \text{ lb./cuft (R-22)} = .033 \text{ lbs/hr or } 289 \text{ lbs/yr}$$

2. How long will it take to detect a leak of 500 lbs/yr of R-22?

$$500 \text{ lbs/yr} = .26 \text{ cuft/hr}$$

$$t = \frac{12000}{6000} \times \ln \left(\frac{.26}{.26 - 25 \times 6000 \times 10^{-6}} \right) = 1.72 \text{ hrs}$$

3. If the trip point is set at 10 ppm, what is the minimum leak rate of R-123 that will trigger the alarm ?

$$\text{LR}_{\min} = 10 \times 6000 \times 10^{-6} = .06 \text{ cuft/hr}$$

$$.06 \times .41 \text{ lbs/ft (R-123)} = .0246 \text{ lbs/hr or } 215 \text{ lbs/yr}$$

4. How long will it take to detect a leak of 300 lbs/yr of R-123 ?

$$300 \text{ lbs/yr of R-123} = .0825 \text{ cuft/hr}$$

$$t = \frac{12000}{6000} \times \ln \left(\frac{.0825}{.0825 - 10 \times 6000 \times 10^{-6}} \right) = 2.6 \text{ hrs}$$

These numbers represent worst case conditions. With the monitor placed close to the potential leak points and on the "downwind" side of the air flow, the trip points are likely to be activated sooner.

Appendix B: SenTech Room Volume Considerations (Metric)

Normal industry practice is to think about refrigerant leaks in terms of weight of refrigerant per unit time such as kg/hr or kg/yr. This is a natural and logical way of looking at it. The system monitors the amount of refrigerant present in the air in Parts Per Million (PPM) by volume of refrigerant per volume of air. In order to develop a relationship between the leak rate in weight per unit time and ppm reading of the monitor, there are a number of items that need to be considered and accounted for. These are:

1. Molecular weight of the refrigerant.
2. Density of the refrigerant at the temperature of the room.
3. Room volume.
4. The rate at which fresh air enters the room.
5. The location of the monitor inlet relative to the leak, the air patterns of the room, and the rate at which the leaking refrigerant expands to fill the room.

For a given specific situation items 1 through 4 are either known, or can be calculated. Item 5 is virtually unknowable, therefore in all the formulas and sample calculations it is assumed that leaking refrigerant expands immediately to fill the room. This is a reasonable and conservative assumption on the basis that you have located the monitor following the recommendations outlined in the installation section. If you have followed those recommendations, the monitor should see a higher concentration sooner than the idealized formulas.

The equations have been developed for two cases. **Case I** is for a sealed room, no air turnover. **Case II** is for a room with a known turnover of air.

To be able to convert between a leak rate in cubic meters per hour to a leak rate in kilograms per hour the density of the refrigerant must be known. At normal atmospheric pressure and room temperature.

$$\text{DENSITY}(\text{kg/m}^3) = \frac{\text{Mol Wt}(\text{gms})}{22.4(\text{ltrs})} \times \frac{273}{293} \times \frac{1(\text{kg})}{1000(\text{gms})} \times \frac{1000(\text{ltrs})}{1(\text{m}^3)}$$

As an example for R-22, Mol Wt = 86.48 gm/mole.
Therefore density = 3.59 kg/m³, or 0.28 m³/kg

Conversion Factors for Common Refrigerants

R-22	3.59 kg/m ³	0.28 m ³ /kg
R-12	4.96 kg/m ³	0.20 m ³ /kg
R-11	5.76 kg/m ³	0.17 m ³ /kg
R-502	4.64 kg/m ³	0.21 m ³ /kg
R-123	6.56 kg/m ³	0.15 m ³ /kg

PPM READINGS AND LEAK RATE RELATIONSHIP

DEFINITIONS:

- PPM = Monitor PPM reading or trip point PPM setting
- LR = Leak Rate of refrigerant in cubic meter per hour
- FA = Fresh Air into the room in cubic meter per hour
- VOL = Volume of the room in cubic meter
- t = Time in hours (There are 8760 hours in one year)
- R = Amount of refrigerant in the room in cubic meters
- LR_{min} = Minimum leak rate that will reach a given PPM

Case I: Sealed Room

$$\text{PPM} = \frac{\text{LR} \times t \times 10^6}{\text{VOL}} \quad t = \frac{\text{PPM} \times \text{VOL} \times 10^{-6}}{\text{LR}}$$

$$R = \text{PPM} \times \text{VOL} \times 10^{-6}$$

Case II: Room with Air Changing

$$\text{PPM} = \frac{\text{LR}}{\text{FA}} (1 - e^{-\frac{\text{LR}}{\text{VOL}} t}) 10^6$$

$$t = \frac{\text{VOL}}{\text{FA}} \times \ln \left(\frac{\text{LR}}{\text{LR} - \text{PPM} \times \text{FA} \times 10^{-6}} \right)$$

$$\text{LR}_{\min} = \text{PPM} \times \text{FA} \times 10^{-6}$$

SAMPLE CALCULATIONS (ASSUMING THE ROOM IS 15 METERS BY 10 METERS BY 3 METERS = 450 CUBIC METERS)

Case I: Sealed Room

1. How much R-22 is necessary to cause a 25 ppm reading ?
 $R = 25 \times 450 \times 10 = .0011$ cubic meter
 $.0011 \text{ m}^3 \times 3.59 \text{ kg/m}^3 \text{ (R-22)} = .004 \text{ kg}$
2. If the leak rate is 150 kg/year of R-22, how long will it take to reach 25 ppm ?

$$\frac{150 \text{ kg}}{\text{yr}} \times \frac{1 \text{ yr}}{8760 \text{ hr}} \times \frac{.28 \text{ m}^3}{\text{kg}} = 0.0048 \text{ m}^3/\text{hr}$$

$$t = \frac{25 \times 450 \times 10}{0.0048} = 2.35 \text{ hrs}$$

Case II: Room with Air Changing

Assume the same room (450 m³).

Assume fresh air at 225 m³/hr (1 air changes in 2 hour).

1. For R-22 what is the minimum leak that will reach 25 ppm ?
 $\text{LR}_{\min} = 25 \times 225 \times 10 = 0.0056 \text{ m}^3/\text{hr}$
 $0.0056 \text{ m}^3/\text{hr} \times 3.59 \text{ kg/m}^3 \text{ (R-22)} = 0.02 \text{ kg/hr OR } 175 \text{ kg/yr}$

2. How long will it take to detect a leak of 200 kg/yr of R-22?

200 kg/yr = 0.023 kg/hr

$$t = \frac{450}{225} \times \ln \left(\frac{.023}{.023 - 25 \times 225 \times 10^6} \right) = 4.0 \text{ hrs}$$

3. If the trip point is set at 10 ppm, what is the minimum leak rate of R-123 that will trigger the alarm ?

$\text{LR}_{\min} = 10 \times 225 \times 10 = .00225 \text{ m}^3/\text{hr}$

$.00225 \times 6.56 \text{ kg/m}^3 = .0148 \text{ kg/hr OR } 130 \text{ kg/yr}$

4. How long will it take to detect a leak of 150 kg/yr of R-123 ?

150 kg/yr of R-123 = .0026 m³/hr

$$t = \frac{450}{225} \times \ln \left(\frac{.0026}{.0026 - 10 \times 225 \times 10^{-6}} \right) = 4.0 \text{ hrs}$$

These numbers represent worst case conditions. With the monitor placed close to the potential leak points and on the "downwind" side of the air flow, the trip points are likely to be activated sooner.

- 1. LPB Board 421034
- 2. Keypad Display 421035
- 3. MMB Board 420033
- 4. RTU-17 Board 420031
- 5. Fuse 3 Amp Fast 410034
- 6. Relay 24 volt 410087

- 7. Pressure switch 420038
- 8. Transformer T1 410039
- 9. Transformer T2 420036
- 10. Coarse Filter 410044
- 11. Manifold 1 Zone 420040
- Manifold 4 Zone 420041
- Manifold 8 Zone 420042

- 12. Diaphragm pump 410224
- 13. 5 micron element 410162
- 14. Filter Assembly 420043
- 17. IR Bench 420030

Not Illustrated

- 010 Orifice 410136-gray
- 9-16z Relay Board OP-002

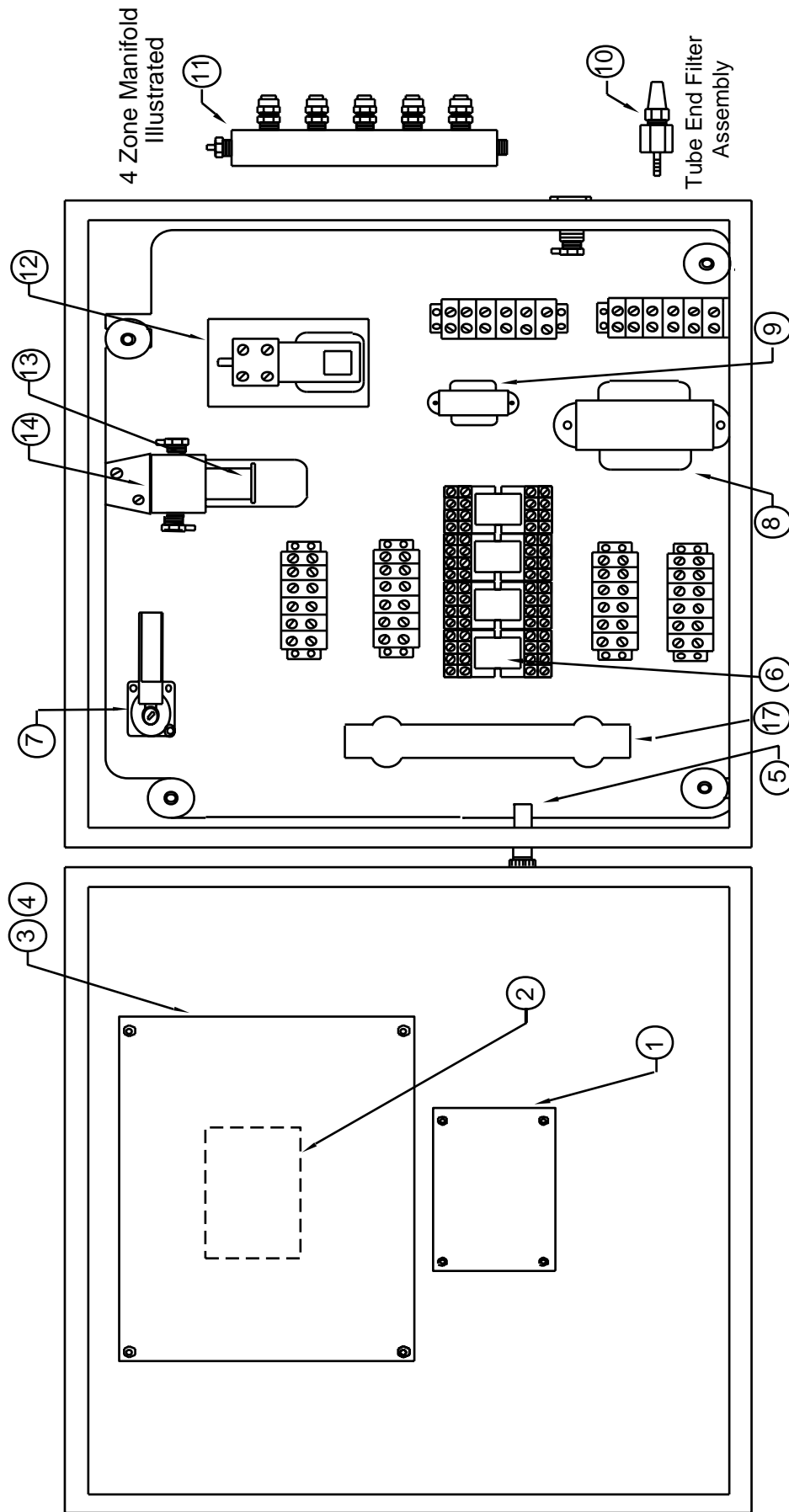

MODELS SSG-MCD1, 4, 8, 16

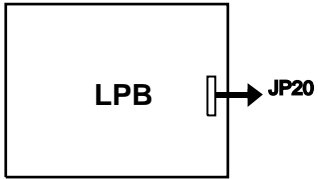
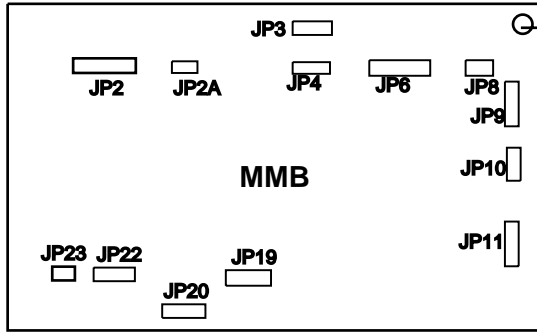

DOOR (REAR VIEW)

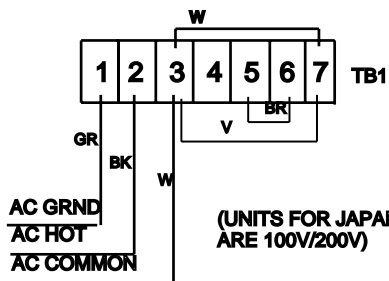

JUMPERS SET FOR 240VAC

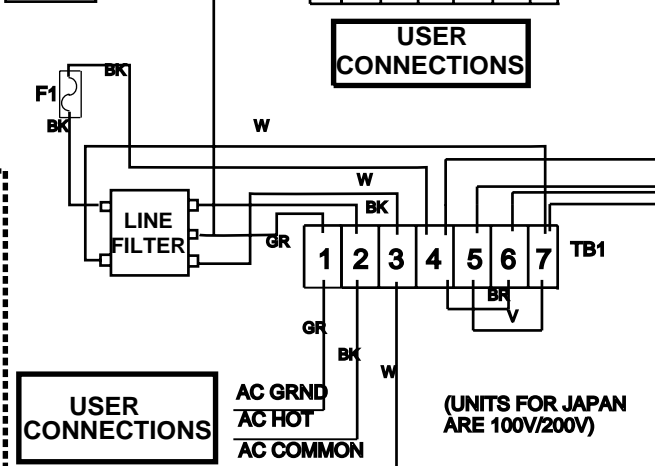
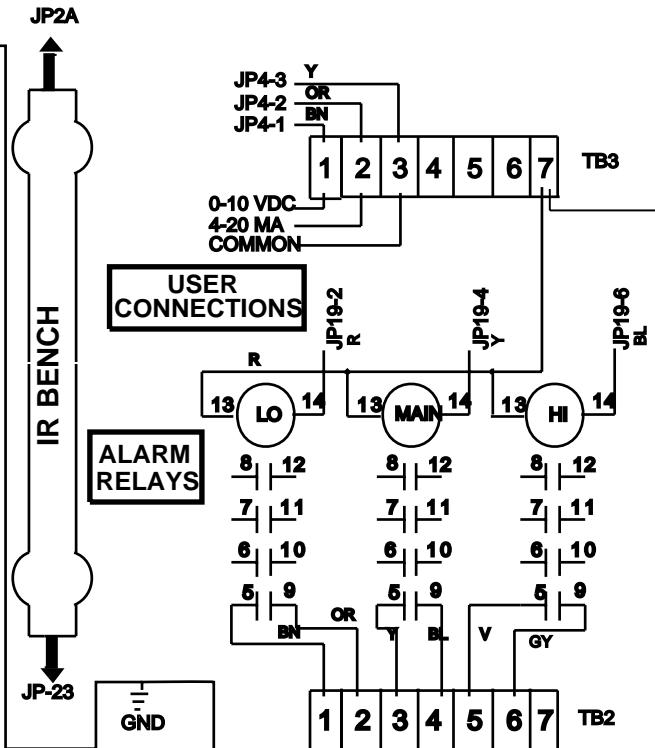

JUMPERS SET FOR 120VAC

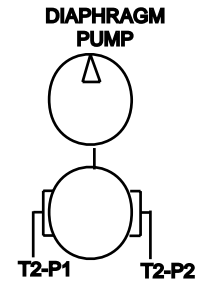

* 4 & 8 ZONE
** 8 ZONE ONLY

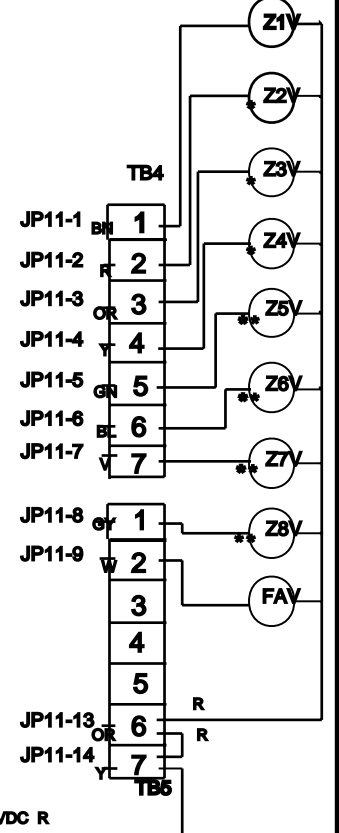
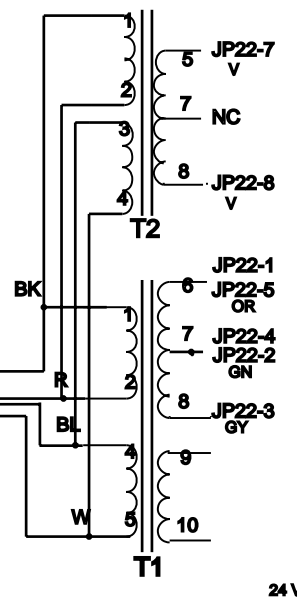
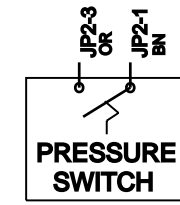

MODEL SNIF-1A, 4A, 8A
WIRING DIAGRAM

Troubleshooting Guide

Before starting, re-familiarize yourself with the START-UP section of the manual. Depending on the problem, you may need to prepare a sample of refrigerant to use in testing. Some of these tests will require the use of a volt/ohm multimeter.

Symptom	Remedy
1. No power.	<ol style="list-style-type: none">1. Check the fuse and replace if failed.2. Check incoming AC Power at TB1-2 and TB1-3 120 (240) Volts AC.
2. Pneumatics Failure.	<ol style="list-style-type: none">1. Check that the diaphragm pump is operating and replace if it has failed.2. Check that the tubing from the diaphragm pump output through the remainder of the circuit is not kinked or has not come loose at any point. Refer to Figure 1.4. Either the orifice or the 5 micron filter or both have become partially or completely blocked or there is a blockage in the tube run for one of the zones.<ol style="list-style-type: none">a). Reset the unit and allow it to cycle through the active zones. If the flow is ok, except in one or more zones, check for blockages in the low flow zone. If the flow is low in all zones, go to b).b). Unscrew the plastic bottle and remove the 5 Micron Filter. Replace the bottle and recheck the flow. If the flow is ok, replace the 5 Micron Filter element.c). If the flow remains low, remove the orifice and clean it by blowing compressed air through it. Recheck the flow. If it is not back to normal, replace the orifice. Note, the orifice must be replaced with the arrow pointing towards the optical bench.
4. Failure to detect a leak/ suspected low sensitivity.	<ol style="list-style-type: none">1. Alarm light is on indicating an alarm, but external alarm devices (horns, lights, etc.) not actuated.<ol style="list-style-type: none">a). Check for 24 volts DC at the alarm relay coil between p13 and p14. If there is no voltage, check that JP19 is properly seated, and there are no loose wires in the alarm relay circuitry.b). If voltage is present, check that the relay is energized by testing for continuity at an unused set of normally open contacts (see diagram on the inside front cover of the enclosure). If the relay is not energized, replace it.c). If the relay is energized, check the wiring to the external devices, and check the devices themselves for proper operation.2. Alarm light(s) not on. Check the trip point settings of the unit to make certain that they are not set too high. If the trip point is too high, reset it and repeat steps 3 through 6 of the start-up procedure to confirm proper operation.3. If steps 1 through 2 have not uncovered the problem, repeat steps 3 through 6 of the start-up procedure. If the system does not respond properly, there has been a failure in the electronics or sensor.4. If all of the checks indicate the unit is operating properly, yet it still believed that a leak was not detected by the system. Review the Location section of the installation procedure. It may be that the pick up point for that zone is not located in an appropriate position, OR THE FRESH AIR PICKUP MAY BE LOCATED IN AN AREA WHERE REFRIGERANT IS PRESENT.

Symptom

Remedy

5. System has gone into alarm and it is believed there is no leak, Flow Failure is NOT indicated.

1. Clear the Alarms and repeat steps 3 through 6 of the start-up procedure. If the unit appears to operate normally, there may have been a transient phenomenon that caused the alarm. Some examples are:
 - a). Someone using a halogen based degreaser such as trichloroethylene near the system.
 - b). A leaky purge that caused a transient increase in the refrigerant level.

Monitor the system closely for the next several weeks to see if it continues to operate normally.

2. If the system goes into alarm yet the reading indicates a very low PPM. Check that the trip point setting has not been changed to 0 PPM or a very low value that is likely to be below ambient conditions. If that is the case, reset the trip point to the appropriate value for your environment, and recheck as in step 1 above.
3. If the system goes into alarm and the reading is above the trip point, there are three likely possibilities:
 - a). There is in fact a leak in the refrigerant system.
 - b). There is a high ambient level of a halogen based hydrocarbon. This may be the result of chemicals stored in the room (such as a leaking refrigerant cylinder).
 - c). The unit has failed.

Disconnect the fresh air tube and allow the unit to Autozero in the same atmosphere as the room. If the unit still goes into alarm, there has likely been a failure in the control board or sensor.

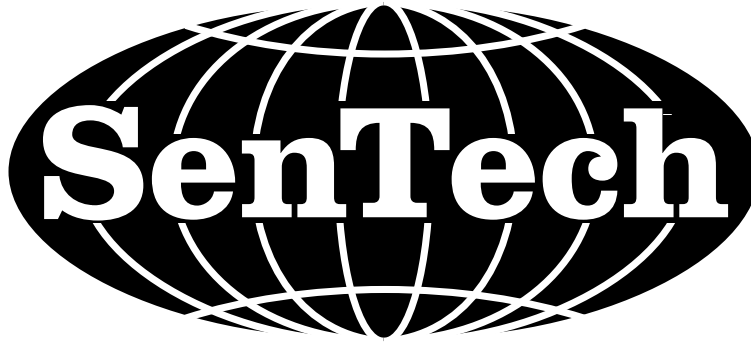

www.sentechcorp.com
Since 1987

SenTech, gives the following as its complete Limited Warranty Statement:

SenTech Manufacturer's Limited Warranty

SenTech warrants to the original purchaser-user that its equipment, as originally supplied, is free from defects in materials and workmanship and will perform adequately under normal use and service, subject to the following conditions and limits:

If the equipment or any part or parts thereof prove to be defective in normal use, then such item or parts will be repaired or replaced at the option of SenTech by SenTech, provided that notice of such defect is given by original purchaser-user to SenTech within one (1) year from the date of original installation (Warranty Registration Must Be On File) or 15 months from the date of sale of the equipment to the original purchaser whichever comes first.

Warranty is made on condition that such original purchaser-user has returned to SenTech the warranty registration form applicable to the equipment, duly and fully completed, within (90) days of the date of purchase by the original purchaser-user.

SenTech's obligation under this warranty is limited exclusively to replacing without charge, or to repairing, at SenTech's option, upon return to Indianapolis, Indiana, transportation charges prepaid, any part or parts that shall be found to be defective in material or workmanship during the warranty period. Charges for labor (except for labor performed by SenTech factory for repairing defective parts) are not covered and these, plus all other costs and expenses for transportation, insurance, etc., shall be paid for by the Warrantee. If, upon inspection by SenTech or its Authorized Service Representative, it is determined that the equipment has not been used in an appropriate manner as described in the SenTech Operator's Manual or has been subject to misuse, alteration, accident, damage during transit or delivery, or that such part is from a machine on which the serial number has been altered or removed, then this warranty is void and of no further force or effect. All decisions regarding the existence of defects in material or workmanship or other causes shall be made by SenTech's Factory Representative and shall be final and binding upon the parties. Returns shall only be made upon the prior written authorization thereof by SenTech.

THE FOREGOING LIMITED WARRANTY IS EXPRESSLY MADE IN LIEU OF ANY AND ALL OTHER WARRANTIES, EXPRESS OR IMPLIED, INCLUDING WITHOUT LIMITATION ANY IMPLIED WARRANTY OF MERCHANTABILITY OR FITNESS FOR A PARTICULAR PURPOSE.

The foregoing limited warranty shall not be enlarged or affected by, and no liability or obligation shall arise from, SenTech's rendering of technical or other advice, or service, in connection with any of its equipment or parts. Employees, agents, distributors, retailers, and sales representatives are not authorized to make warranties. Oral or written statements made may them do not constitute warranties and shall not be relied upon.

REPLACEMENT OR REPAIR OF DEFECTIVE EQUIPMENT OR PARTS AS PROVIDED ABOVE IS THE ORIGINAL PURCHASER-USER'S SOLE AND EXCLUSIVE REMEDY FOR CONTRACT, WARRANTY, NEGLIGENCE, TORT OR STRICT LIABILITY CLAIMS FOR ANY LOSS, DAMAGE OR EXPENSE ARISING OR ALLEGED TO ARISE OUT OF THE DESIGN, MANUFACTURE, SALE, DELIVERY OR USE OF SUCH EQUIPMENT AND/OR PARTS. IN NO EVENT SHALL SENTECH BE LIABLE FOR ANY AMOUNT IN EXCESS OF THE PURCHASE PRICE OF THE EQUIPMENT, OR FOR LOSS OF USE OR PROFITS, LOSS OF BUSINESS INTERRUPTION, ATTORNEY'S FEES, OR CONSEQUENTIAL, CONTINGENT, INCIDENTAL OR SPECIAL DAMAGES CAUSED OR ALLEGED TO CAUSED IN WHOLE OR IN PART BY THE NEGLIGENCE, TORT, STRICT LIABILITY, BREACH OF CONTRACT, BREACH OF WARRANTY, OR OTHER BREACH OF DUTY OF OR BY SENTECH.

SenTech Corporation
5745 Progress Road
Indianapolis, Indiana 46241

THIS LIMITED WARRANTY IS NOT TRANSFERABLE.

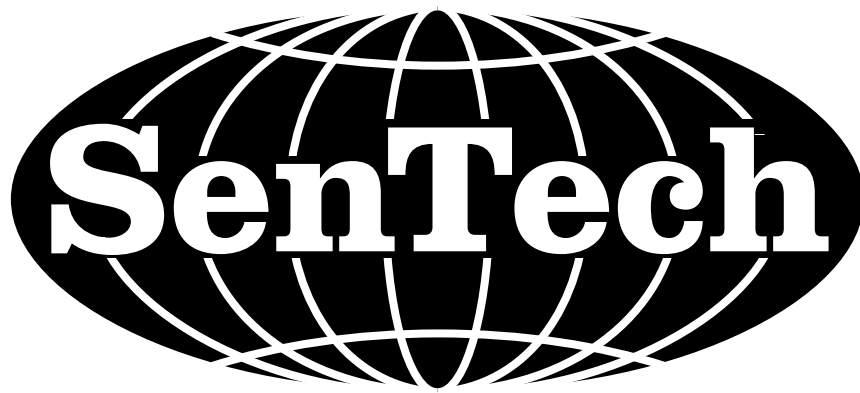

P/N SSG-MCDITS
11-/28/02